

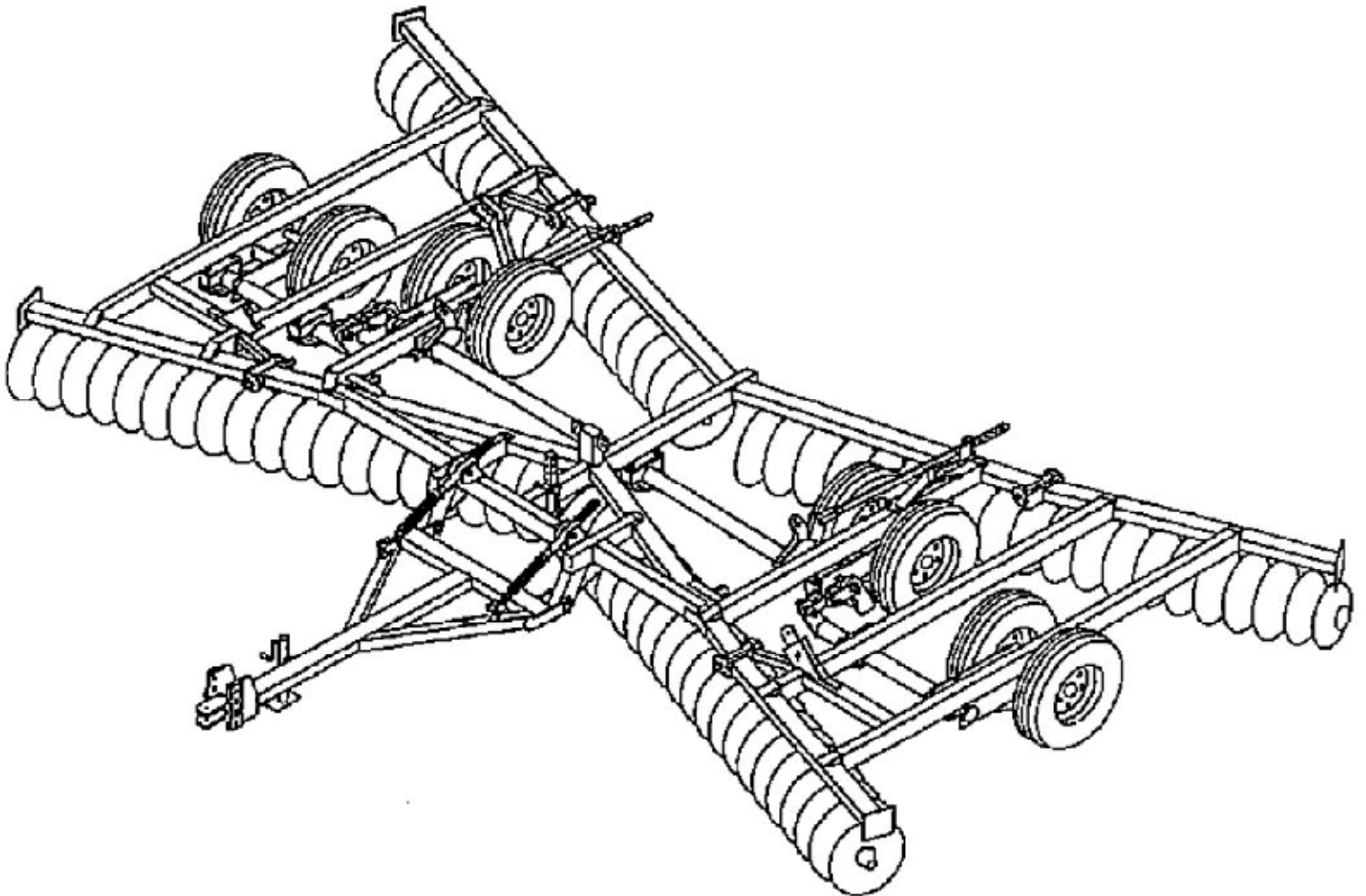

TAYLOR PITTSBURGH MFG., INC.  
PO BOX 1200  
WINFIELD, AL 35594  
205-487-3202

# 580 SERIES FLEX WING TANDEM DISC HARROW



OWNER'S MANUAL

OCTOBER 2023

# TABLE OF CONTENTS

INTRODUCTION .....	1
WARRANTY .....	1
SAFETY SYMBOLS .....	2
GENERAL INFORMATION .....	3
SPECIFICATIONS .....	4
SAFETY RULES .....	5-7
BOLT TORQUE CHART .....	3
SAFETY DECALS & LOCATION .....	8
OPERATION .....	9
ASSEMBLY .....	9-16
ADJUSTMENTS .....	16
MAINTENANCE .....	17
BEFORE OPERATION .....	17-18
ATTACHING .....	18
OPERATION .....	18
TRANSPORTING .....	19
REMOVING HARROW FROM TRACTOR .....	19
LUBRICATION .....	19
STORAGE .....	19
BALK BREAKER ASSEMBLY .....	19
TROUBLESHOOTING .....	20
DISC & BRG. CONFIGURATION .....	22-27
REPAIR PARTS LISTS .....	28-43

## **TO THE DEALER:**

The disk harrow assembly and proper installation to the tractor is the responsibility of the TAYLOR PITTSBURGH dealer. Read manual instructions and safety rules. Make sure all items on the Pre-delivery and Delivery Check Lists are completed before releasing equipment to the owner.

## **TO THE OWNER:**

Read this manual before operating your TAYLOR PITTSBURGH disk harrow. The information presented will prepare you to do a better and safer job. Keep this manual handy for ready reference. Require all operators to read this manual carefully and become acquainted with all the adjustment and operating procedures before attempting to operate. Replacement manuals can be obtained from your dealer or by calling 1-800-228-2308, in the USA and Canada only.

The disk harrow you have purchased has been carefully engineered and manufactured to provide dependable and satisfactory use. Like all mechanical products, it will require cleaning and upkeep. Lubricate the unit as specified. Observe all safety information in this manual and safety decals on the disk harrow and tractor.

For service, your authorized TAYLOR PITTSBURGH dealer has trained mechanics, genuine TAYLOR PITTSBURGH service parts, and the necessary tools and equipment to handle all your needs.

Provide this information to your dealer to obtain correct repair parts.

## **LIMITED WARRANTY**

TAYLOR PITTSBURGH MFG., INC., the manufacturer, warrants only to the Original Purchaser that this equipment, under normal use and service, will be free from defects in material and workmanship for one (1) year from date of purchase providing this equipment is purchased for individual and not for commercial use. Warranty for commercial usage is 90 days. This warranty does not apply to any equipment which has been damaged or which has been subjected to abuse, misuse, negligence, abnormal wear and tear, alterations, tampering, or failure to follow operating instructions. This warranty does not cover any product or parts not manufactured by Taylor Pittsburgh Manufacturing, Inc..

Under this warranty, the manufacturer will repair or replace any part which the manufacturer determines has failed during the period of the warranty due to defects in material or workmanship. After approval by the manufacturer, the equipment or defective part must be returned to Taylor Pittsburgh Mfg., Inc., Winfield, Alabama 35594

**PURCHASER'S EXCLUSIVE REMEDY FOR BREACH OF WARRANTY, OTHER DEFECT, OR CONDUCT GIVING RISE TO LIABILITY SHALL BE THE REPAIR OR REPLACEMENT OF THE PRODUCT SOLD, AND THE MANUFACTURER UNDER NO CIRCUMSTANCES SHALL BE LIABLE FOR ECONOMIC LOSS OR INCIDENTAL OR CONSEQUENTIAL DAMAGES. THE MANUFACTURER DISCLAIMS ALL IMPLIED WARRANTIES, INCLUDING THE WARRANTY OF MERCHANTABILITY AND FITNESS FOR PURPOSE.**

Taylor Pittsburgh Mfg., Inc. reserves the right to make improvements and changes in specifications without notice or obligation to modify previously sold units.

This manual describes the proper assembly procedures for your disk harrow and furnishes operating and maintenance recommendations to help you obtain long and satisfactory service.

# SAFETY RULES



**ATTENTION! BECOME ALERT! YOUR SAFETY IS INVOLVED!**



## SAFETY ALERT SYMBOL

**FIG. 1:** This is the safety alert symbol. It means **ATTENTION: BECOME ALERT! YOUR SAFETY IS INVOLVED!** Look for it, both in this manual and on safety decals on the equipment. It will direct your attention to information that involves your safety and the safety of others.



## SIGNAL WORDS

**FIG. 2:** The words **DANGER**, **WARNING** or **CAUTION** are used with the safety alert symbol. Learn to recognize these safety alerts, and follow the recommended precautions and safe practices.



**DANGER:** The safety alert symbol, with the word **DANGER**, indicates an imminently hazardous situation that, if not avoided, will cause **DEATH OR VERY SERIOUS INJURY**.



**WARNING:** The safety alert symbol, with the word **WARNING**, indicates a potentially hazardous situation that, if not avoided, could cause **DEATH OR SERIOUS INJURY**.



**CAUTION:** The safety alert symbol, with the word **CAUTION**, indicates a potentially hazardous situation that, if not avoided, may cause a **MINOR INJURY**.

Replace any **DANGER**, **WARNING**, **CAUTION** or instructional decal that is not readable or is missing. The location and part number of these decals is identified later in the section of the

**IMPORTANT:** The word **IMPORTANT** is used to identify special instructions or procedures which, if not strictly observed could result in **damage to, or destruction of the machine, process or its surroundings**.

Figure 1



Figure 2

# GENERAL INFORMATION

## INTRODUCTION

**READ THIS MANUAL** carefully to learn how to operate and service your harrow correctly. Failure to do so could result in personal injury or equipment damage.

Throughout this manual, references are made to right and left direction. **RIGHT - HAND AND LEFT - HAND** sides are determined by standing behind the harrow facing the direction the harrow will travel when going forward.

The purpose of this manual is to assist you in operating and maintaining your Series 580 Tandem Disc Harrow. Read it carefully. It furnishes information and instructions that will help you achieve years of dependable performance. These instructions have been compiled from extensive field experience and engineering data. Some information may be general in nature due to unknown and varying operating conditions.

However, through experience and these instructions, you should be able to develop procedures suitable to your particular situation.

Maintain your implement with original repair parts to insure safety and optimum performance.

## WARNING

- Some illustrations in this manual show the harrow with safety components removed to provide a better view. The harrow should never be operated with any safety components removed.

The illustrations and data used in this manual were current at the time of printing, but due to possible production changes, your harrow may vary slightly in detail. We reserve the right to redesign and change the machines as may be necessary without notification.

## BOLT TORQUE CHART

GRADE 2



GRADE 5



GRADE 8

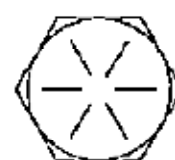

## TORQUE IN FOOT POUNDS (NEWTON METERS)

BOLT SIZE	3/8	1/2	5/8	3/4	7/8	1	
HEX HEAD	9/16	3/4	15/16	1-1/8	1-5/16	1-1/2	
GRADE	2	18 (24.4)	45 (61.0)	89 (120.7)	160 (216.9)	252 (341.6)	320 (433.9)
	5	30 (40.6)	68 (92.2)	140 (189.8)	240 (325.4)	360 (488.1)	544 (737.5)
	8	40 (54.2)	100 (135.6)	196 (265.7)	340 (460.9)	528 (715.1)	792 (1073.8)

Rigid Brg Models (580-S)	Spring Brg Models (580-F)	Cutting Width	Number Of Discs	Approx. Weight Rigid Brg	Approx. Weight Spring Brg	Disc Spacing	Drawbar Horsepower Requirement
580-S-52-88	580-F-52-88	17ft. 5in.	52	7158	7390	8" F - 8" R	125
580-S-54-88	580-F-54-88	17ft. 5in.	54	7131	7673	8" F - 8" R	130
580-S-62-88	580-F-62-88	19ft. 11in.	62	7522	7902	8" F - 8" R	135
580-S-68-88	580-F-68-88	22ft. 6in.	68	8111	8074	8" F - 8" R	150
580-S-70-88	580-F-70-88	22ft. 6in.	70	8430	8517	8" F - 8" R	160
580-S-76-88	580-F-76-88	25ft.	76	8454	8834	8" F - 8" R	180
580-S-78-88	580-F-78-88	25ft.	78	8884	9190	8" F - 8" R	180
580-S-48-99	580-F-48-99	17ft. 11in.	48	7049	7309	9" F - 9" R	120
580-S-56-99	580-F-56-99	20ft. 9in.	56	7399	7779	9" F - 9" R	130
580-S-60-99	580-F-60-99	22ft. 2in.	60	7912	8292	9" F - 9" R	140
580-S-68-99	580-F-68-99	25ft.	68	8334	8334	9" F - 9" R	150
580-S-52-98	580-F-52-98	17ft. 5in.	52	7090	7350	9" F - 8" R	120
580-S-60-98	580-F-60-98	21ft. 2in.	60	7482	7862	9" F - 8" R	140
580-S-64-98	580-F-64-98	22ft. 6in.	64	7482	8373	9" F - 8" R	150
580-S-72-98	580-F-72-98	25ft.	72	8342	8722	9" F - 8" R	175

### MODELS WITH DELTA TYPE AXLES AND RIGID BRG. HANGERS

Delta Model	Number of Discs	Approx. Weight	Disc Spacing	Drawbar Horsepower Requirement
58601	52 (26F, 26R)	5650	8"	100
58602	60 (30F, 30R)	6100	8"	110
58603	68 (34F, 34R)	6650	8"	125
58604	76 (38F, 38R)	7225	8"	140
58605	48 (24F, 24R)	6000	9"	100
58606	56 (28F, 28R)	6350	9"	110
58607	60 (30F, 30R)	6670	9"	125
58608	68 (34F, 34R)	7050	9"	140
58609	50 (24F, 26R)	5930	9" F, 8" R	100
58610	58 (28F, 30R)	6290	9" F, 8" R	110
58611	64 (30F, 34R)	6660	9" F, 8" R	125
58612	72 (34F, 38R)	7375	9" F, 8" R	140

## SAFETY RULES



**ATTENTION! BECOME ALERT! YOUR SAFETY IS INVOLVED!**



Safety is a primary concern in the design and manufacture of our products. Unfortunately, our efforts to provide safe equipment can be wiped out by a single careless act of an operator.

In addition to the design and configuration of equipment, hazard control and accident prevention are dependent upon the awareness, concern, prudence and proper training of personnel involved in the operation, transport, maintenance and storage of equipment.

It has been said "The best safety device is an informed, careful operator." We ask you to be that kind of an operator.

The designed and tested safety of this equipment depends on it being operated within the limitations as explained in this manual.

### TRAINING

• **Safety instructions are important! Read this manual and the tractor manual; follow all safety rules and safety decal information. (Replacement manuals are available from dealer or call 1-800-228-2308) Failure to follow instructions or safety rules can result in serious injury or death.**

• **If you do not understand any part of this manual and need assistance, see your dealer.**

• **Know your controls and how to stop engine and attachment quickly in an emergency.**

• **Operators must be instructed in and be capable of the safe operation of the equipment, its attachments and all controls. Do not allow anyone to operate this equipment without proper instructions.**

**Do not allow children or untrained persons to operate equipment.**

### PREPARATION

• **Always wear relatively tight and belted clothing to avoid entanglement in moving parts. Wear sturdy, rough-soled work shoes and protective equipment for eyes, hair, hands, hearing and head.**

• **Ensure implement is properly mounted, adjusted and in good operating condition.**

• **Tighten all bolts, nuts and bolts, and check that all cotter pins are installed securely to ensure equipment is in a safe condition before operating.**

• **Tractor must be equipped with ROPS or ROPS CAB and seat belt. Keep seat belt securely fastened. Falling off tractor can result in death from being run over or crushed. Keep foldable ROPS systems in "locked up" position at all times.**

• **Remove accumulated debris from this equipment, tractor and engine to avoid fire hazard.**

• **Ensure all safety decals are installed. Replace if damaged. (See Safety Decals section for location.)**

### OPERATIONAL SAFETY

• **Operate only in daylight or good artificial light.**

• **Keep bystanders away from equipment while it is in operation.**

• **Always comply with all state and local lighting and marking requirements.**

• **No riders are allowed on equipment.**

• **Always sit in tractor seat when operating controls or starting engine. Place transmission in park or neutral, engage**

*(Safety Rules continued on next page)*



## SAFETY RULES



**ATTENTION! BECOME ALERT! YOUR SAFETY IS INVOLVED!**

*(Safety Rules continued from previous page)*

- Look down and to the rear and make sure area is clear before operating in reverse.
- Do not operate on steep slopes.
- Do not stop, start or change directions suddenly on slopes.
- Use extreme care and reduce ground speed on slopes and rough terrain.
- Watch for hidden hazards on the terrain during operation.
- Stop tractor and implement immediately upon striking an obstruction. Turn off engine, remove key, inspect and repair any damage before resuming operation.
- Disengage power to implement. Lower all raised components to the ground. Operate valve levers to release any hydraulic pressure. Stop engine, set parking brake and remove key before dismounting tractor or performing any service or maintenance.

### MAINTENANCE SAFETY

- Before working underneath, raise harrow to highest position, install transport locks, and block securely. Blocking up prevents harrow dropping from hydraulic leak down, hydraulic system failures, or mechanical component failures.
- Serious injury can be inflicted by disc blades and disc gangs if not handled safely. Watch for unsafe conditions. Keep your coworkers safety in mind. Do not handle disc blades with bare hands.
- Keep all persons away from operator control area while performing adjustments, service or maintenance.
- Your dealer can supply genuine replacement disc blades. Substitute blades may not meet original equipment specifications.
- Do not climb or walk on harrow frame, or tires.

- Do not stand on or straddle a tongue when unhitching.
- Never operate harrow until hydraulic cylinders and lines are full of oil and free of air. See operating instructions.

### TRANSPORTING SAFETY

- Use a Slow - Moving - Vehicle (SMV) emblem and proper lighting when transporting the harrow.
- Always use a safety chain of tensile strength equal to the gross weight of the disc harrow plus any attachments when transporting. Make sure that the weight of the towing vehicle EXCEEDS the weight of the harrow being towed. Stopping distance increases with increasing speed as the weight of the towed load increases, especially on hills and slopes.
- Check tire pressure and wheel bolts before and during transport.
- Always use transport locks to hold harrow in raised position and wings folded.
- Do not road the harrow over 20 miles per hour on the best surface conditions. Reduce speed when going up or down hills and when approaching ditches or corners. Towing vehicle must weigh more than towed implement.
- Check condition of hitch pins and bolts, tires and hubs, and safety chain before transporting.
- Keep your harrow in proper working condition. Unauthorized modifications to the harrow may impair the function and/or safety and affect harrow life. Do not add excessive weight to harrow. Additional weight could cause frame or axle to fail resulting in loss of control of harrow/tractor during transport.

*(Safety Rules continued on next page)*



## SAFETY DECALS

**⚠ ATTENTION! BECOME ALERT! YOUR SAFETY IS INVOLVED! ⚠**  
**Replace Immediately If Damaged!**

*(Safety Rules continued from previous page)*

- Watch low hanging Overhead Power Lines during transport. Avoid contact as this can cause serious injury or death.

### STORAGE

- Block equipment securely for storage.
- Keep playing children and bystanders away from storage area.

## BOLT TORQUE CHART

### GRADE 2

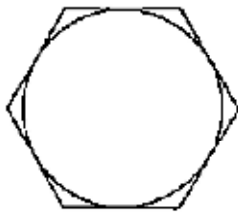

### GRADE 5



### GRADE 8

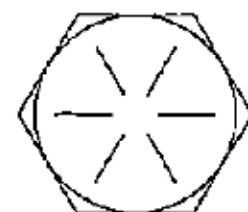

## TORQUE IN FOOT POUNDS

BOLT SIZE	3/8	1/2	5/8	3/4	7/8	1	
HEX HEAD	9/16	3/4	15/16	1-1/8	1-5/16	1-1/2	
GRADE	2	18	45	89	160	252	320
	5	30	68	140	240	360	544
	8	40	100	196	340	528	792



# SAFETY DECALS



**ATTENTION! BECOME ALERT! YOUR SAFETY IS INVOLVED!**  
**Replace Immediately If Damaged!**



029770 amber reflector front side ends of front gang tubes



029771 red reflector rear side end of rear LH gang tube

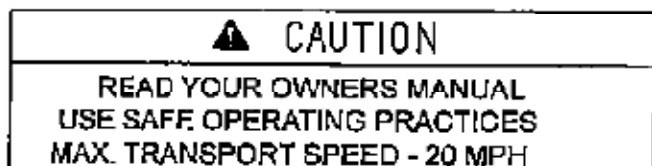

009537 Left front center frame



029775 Left front center frame



605176 Left front center frame

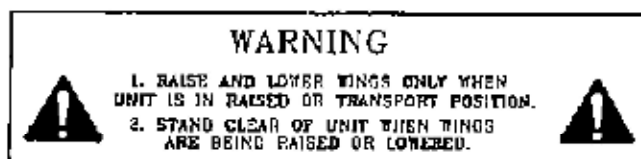

605177 Left front center frame



029772 Gang tube near wing hinge

# OPERATION

Safety is a primary concern in the design and manufacture of our products. Unfortunately, our efforts to provide safe equipment can be wiped out by a single careless act of an operator.

In addition to the design and configuration of equipment, hazard control and accident prevention are dependent upon the awareness, concern, prudence and proper training of personnel involved in the operation, transport, maintenance and storage of equipment.

It has been said "The best safety device is an informed, careful operator." We ask you to be that kind of an operator.

The operator is responsible for the safe operation of this harrow. The operator must be properly trained. Operators should be familiar with the harrow and tractor and all safety practices before starting operation. Read the safety information on pages 3 through 4.

This harrow is designed for normal farm usage. Optional blades with are available for different conditions.

Recommended harrowing speed for most conditions is from two to five mph.

Maintain your implement with original repair parts to insure safety and optimum performance.

## ASSEMBLY

### **General**

Your Series 580 Tandem Disc Harrow is shipped in bundles for assembly. Remove all wiring from bundles as they are called for. Choose a level area to arrange the parts conveniently. Assemble parts for each step loosely to insure fit. Use flatwashers with slotted holes. Always use lockwashers unless a lock nut is called for. Tighten hardware after parts are installed according to the torque chart given. Unless otherwise stated, all hardware is grade 5. The following assembly steps are given to minimize the need for adjustment after assembly. Remember that **LEFT** and **RIGHT** are determined by standing at the rear of the

### **Center Frame Preparation**

You will need four (4) jack stands set at 33" from base to top supporting surface to block up frame.

**When assembling do not tighten hardware until total assembly is complete.**

1) Place center frame wheel lift in the center of the assembly area with the wheel hubs to the rear.

2) Place center frame with hydraulic circuit manifold up above the wheel lift on jack stands near the four corners approximately 33" off ground. Place supports so as not to interfere with wheel axle connections.

### **Center Frame Wheel (See Figure 1)**

1) Remove wheel lift bolts and lift roll bearings from center frame.

2) Raise wheel lift assembly to the center frame making sure to have a bearing half positioned on the wheel lift below each frame member with cylinder bracket up and hubs to the rear. Locate the top halves of the wheel lift bearings on wheel axle tube with the grease fittings facing rearward. Align wheel lift with bearing plates on center frame. Replace lower bearing cap, 7/8" x 6" bolts, lockwashers, and nuts. Do not tighten hardware until axle is correctly positioned.

3) Raise wheel lift and mount wheels to hubs. Lower wheel lift onto wheels. Be sure to tighten all lug nuts.

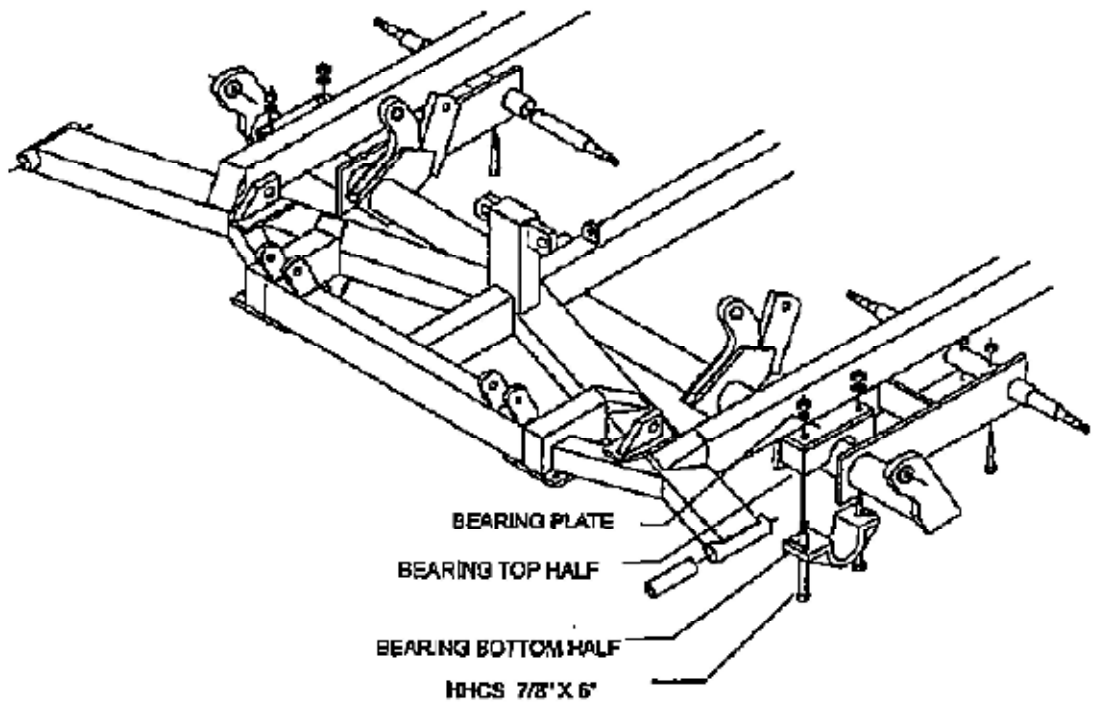

FIGURE 1 - WHEEL LIFT BEARING ASSEMBLY

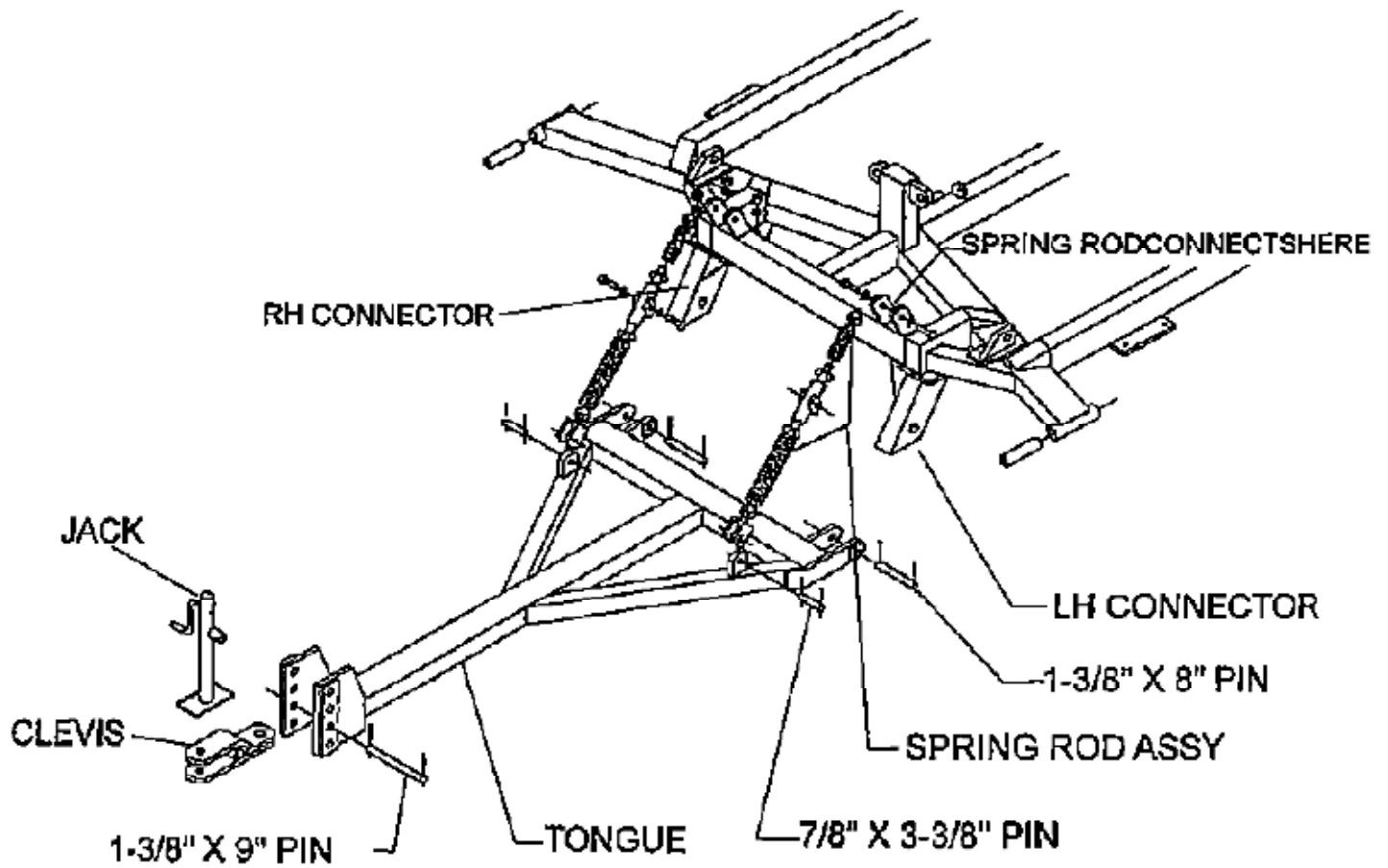

FIGURE 2 - TONGUE ASSEMBLY

### Tongue Assembly (Fig 2)

- 1) Align tongue with connectors making sure spring rod mounts are up. Mount tongue to connectors using pins provided. Secure with cotter pins.
- 2) Install jack and use to support tongue.
- 3) Pin the spring rod assemblies to the tongue with the pins provided. Secure with cotter pins.
- 4) Remove the shoulder bolts from the slide assemblies and rotate the slides so the grease fittings are up.
- 5) Insert the slide assemblies into the brackets on the front of the main frame. Align the holes in the slide assemblies with the holes in the brackets. This can be done by rotating the nuts on the spring rod and by adjusting tongue height with the jack.
- 6) Insert the shoulder bolts with lockwashers into the brackets and tighten.

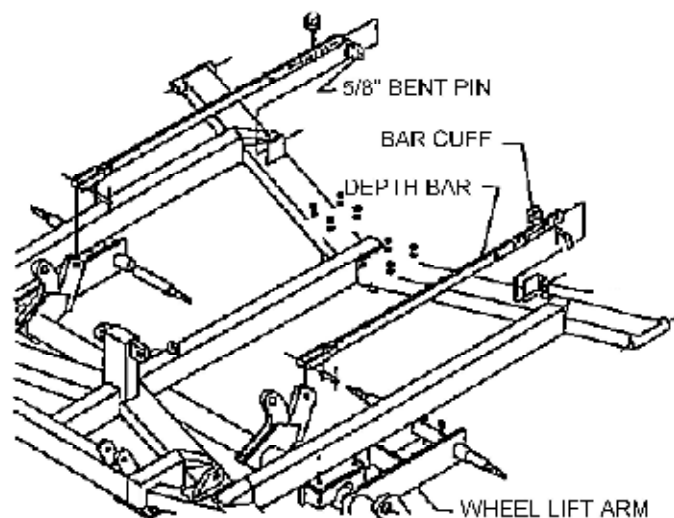

FIGURE 3 - DEPTH CONTROL ASSEMBLY

### Wing Assembly (Fig 4)

- 1) Position left hand wing with long gang frame to the rear. Align clevis with tube on main frame.
- 2) Remove pins from wing hinges.
- 3) Align wing with main frame to allow connection. Insert pins from the outside to lock against the keystone and secure with cotter pin.
- 4) Repeat procedure for the right wing.

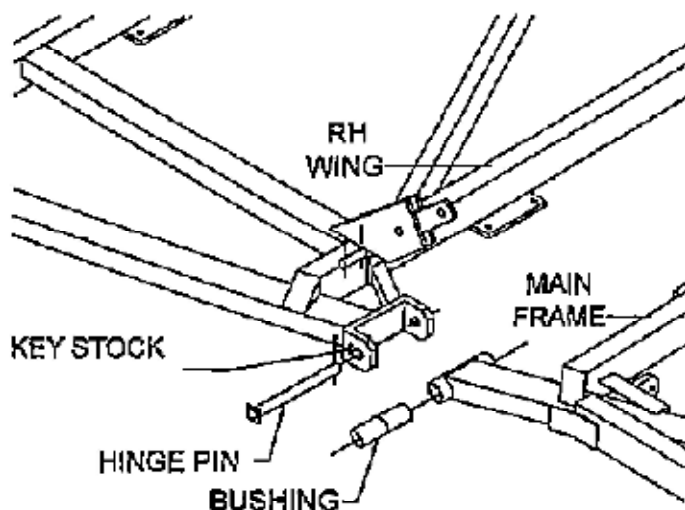

FIGURE 4 - WING HINGE ASSEMBLY

### Depth Control Assembly (Fig 3)

- 1) Remove bent pin and depth control cuff from the two depth gauge bars.
- 2) Slide the end of each bar through the main frame cuff and pin the clevis end of each bar to the wheel lift arm on the main frame wheel lift rocker as shown.
- 3) Replace the depth cuff behind the bracket on the main frame. Secure bent pin with hairpin cotter.

### Wing Extensions (Figure 5)

If your harrow does not have wing extensions, proceed to the next section.

- 1) Remove hardware from extensions.
- 2) Align extensions with plates on outside corners of wings. Replace hardware and tighten.

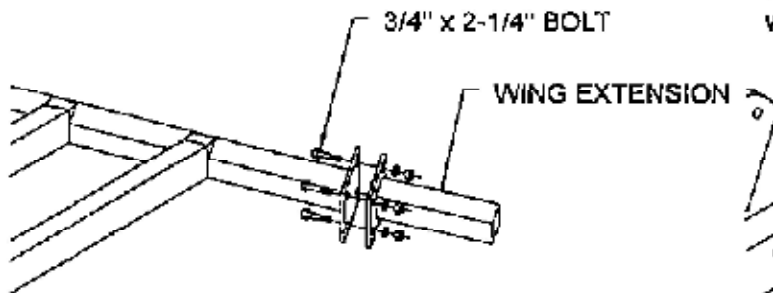

FIGURE 5 - WING EXTENSION ASSEMBLY

### Wing Wheel Lift Assembly

- 1) Slide the wing wheel axle assemblies under wings with hubs to the outside and wheel hubs rearward. On large wing harrows, axles have 2 wheel hubs.
- 2) Remove wheel lift bolts and lift roll bearings from wing frame.
- 3) Raise wheel lift assembly to the wing frame making sure to have a bearing half positioned on the wheel lift below each frame member with cylinder bracket up and hubs to the rear. Locate the top halves of the wheel lift bearings on wheel axle tube with the grease fittings facing rearward. Align wheel lift with bearing plates on wing frame. Replace lower bearing cap, 7/8" X 6" bolts, lockwashers, and nuts. Do not tighten hardware until axle is correctly positioned.
- 4) Raise wheel lift and mount wheels to hubs. Lower wheel lift onto wheels. Be sure to tighten all lug nuts.

### Wheel Lift Connectors (Figure 6)

The wheel lift connectors are located on the wing axes.

- 1) Make sure harrow is level across the frame including the wings.
- 2) Remove the pin from the free end of the connector. Adjust the connector to align clevis with hole in wing bracket. Insert pin and secure with cotter pins.

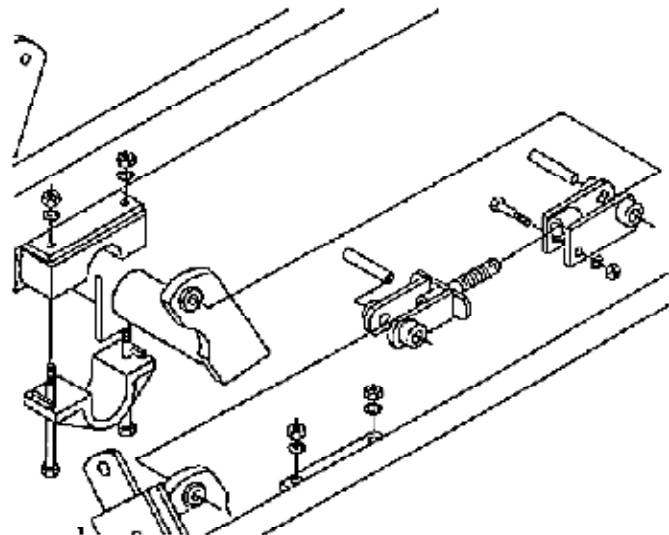

FIGURE 6 - WHEEL LIFT CONN. ASSEMBLY

### ⚠ WARNING

- Wear heavy gloves and boots when handling gangs to avoid injury. Blades are extremely sharp.

### Gang Assembly

- Find the gang layout for your model. Use this diagram to determine the positions of the gang assemblies.
- To help determine gang positions, remember that the scrapers go to the rear. This means that the scraper brackets must point toward the rear when the gang is correctly positioned. Also remember that the rear gang blades are cupped to the inside and front gang blades are cupped to the outside.

## Hydraulic Circuit Assembly (Figure 7)

Use a thread sealant on fittings to prevent leaking. DO NOT OVER TIGHTEN.

### General

- When installing hydraulic hoses, note that only one end of the hose swivels, therefore always connect the non swivel end first.
- Always use a thread sealant when connecting fittings and hoses to prevent leaks.
- Do not over tighten fittings.

1) Connect the base end of the two 4" x 8" hydraulic cylinders to the brackets on the main frame. Be sure the hydraulic line ports are positioned to the inside.

2) Remove the plugs from the two line ports to allow extension of the cylinder rods.

3) Connect the rod end of each cylinder to the brackets on the wheel lift.

4) Connect the base end of the two 4" x 24" cylinders to the brackets on the main frame. Be sure to position the line ports to the front of the harrow,

5) Extend wing cylinder and connect to bracket on wing.

**Note:** Flow restrictors should already be installed in at least one of the line ports. If not, see your dealer to obtain flow restrictors for these cylinders.

### WARNING

Without flow restrictors in wing cylinders, the wings will drop rapidly when lowered and could cause serious injury and damage the harrow.

6) Install 90° elbows in both ports of the wheel lift cylinders. Tighten with ends pointed forward.

### WARNING

Do not use bare hand to check for leaks. Hydraulic fluid under high pressure can penetrate skin and cause poisoning.

7) Install 90° elbows in the wing lift cylinders. Tighten with ends pointing to the inside.

### Installing Hydraulic Hoses:

Each hose has only one swivel end so it is important to connect the end without the swivel first. Always tighten each hose end as it is connected before proceeding. Use a thread sealant on fittings to prevent leaking. DO NOT OVER TIGHTEN.

When connecting hoses from the cylinders to the manifold, be sure common hoses are paired opposite each other on the manifold as shown.

1) Separate the hoses by length.

2) Connect a 24" hose from the base end of each wing cylinder to the top hole in the side of the manifold.

3) Connect a 38" hoses from the rod port of each wing cylinder to the second hole from top in manifold.

4) Connect a 38" hose from the base end of each transport lift cylinder to the bottom hole in the manifold.

5) Connect a 46" hose from the rod port of each transport lift cylinder to the second hole from bottom in the manifold.

6) Connect four 88" hoses from the frame manifold to the tongue header near the front of the tongue. Connect the first hose from the top port in the manifold to the far right hand port in the header. Connect the next hose from the port second from top to the header port second from far right and so forth. Anchor the hoses to the tongue using the clamp assembly provided.

7) Hoses from header to tractor are not supplied.

### Attaching Tractor to Disc Harrow

1) Back tractor to align drawbar with clevis.

2) Attach hitch to drawbar with a high strength drawbar pin and secure with a clip pin.

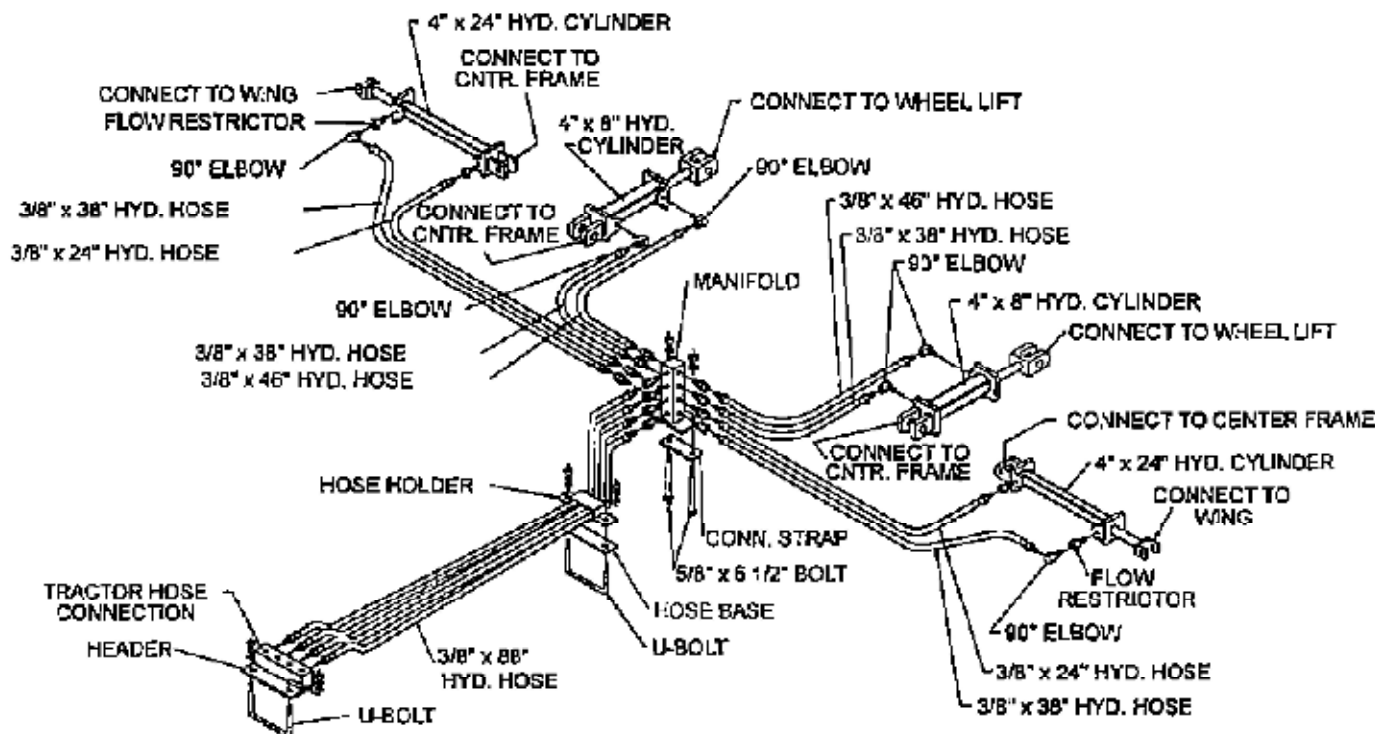

FIGURE 7 - HYDRAULIC CIRCUIT ASSEMBLY

**⚠ WARNING**

Be sure bystanders are clear. Do not stand between implement and tractor. Shut off tractor and engage parking brake prior to dismounting.

- 3) Attach hydraulic hoses to your tractor. The upper two hoses control the wing fold and the lower two hoses control the wheel lift.
- 4) Attach safety chain to tractor. Allow enough slack to turn.

**⚠ WARNING**

DO NOT raise wings without flow restrictors. Wings will fall rapidly while lowering, and could cause serious injury or death.

**Hydraulic System Checkout**

It will require about 6 gallons of hydraulic fluid to fill the system. Use tractor manufacturers recommendation on hydraulic fluid.

Check that all hydraulic connections are tight.

It is important that all air be out of the hydraulic system before performing wheel lift and wing fold.

**⚠ WARNING**

Check for small high pressure leaks by passing a piece of cardboard or wood over lines rather than hands. High pressure oil can penetrate skin and can only be removed surgically.

**⚠ WARNING**

Be sure bystanders are clear before lifting wings. Do not walk under raised wings for any reason. Do not stand between implement and tractor. Hydraulic or mechanical failure can allow wings to drop suddenly and unexpectedly.

At this point the harrow can be lifted off its supports. This will allow height adjustment of the harrow to aid in gang assembly.



## **WARNING**

Wear heavy gloves and boots when handling gangs to avoid injury. Blades are extremely sharp.

### **Gang Assembly**

- Find the gang layout for your model. Use this diagram to determine the positions of the gang assemblies.

- To help determine gang positions, remember that the scrapers go to the rear. This means that the scraper brackets must point toward the rear when the gang is correctly positioned. Also remember that the rear gang blades are cupped to the inside and front gang blades are cupped to the outside.

- The two outside front gangs are those with one outside blade 2" smaller than the rest. The two outside rear gangs are those with two outside blades smaller than the rest, 1 - 2", 1 - 4". Locate these gangs first.

- Attach all front gangs starting from the center and working outward. Bring the center two gangs in as close as possible to each other to eliminate balk. Be sure these gangs are evenly positioned on main frame. When attaching consecutive gangs, space them 8" or 9" from each other depending on disk spacing. Tighten all hardware as each gang is installed.

- Position the two inside rear gangs centered on main frame with about 18" between the two inside blades at the closest point. Be sure these gangs are evenly positioned on main frame. Tighten all hardware as each gang is installed.

#### **Conventional Rigid Hanger Gangs:**

The top of the rigid hanger should point to the rear of the harrow when the gang is correctly positioned.

- 1) Remove U-bolts from top of hangers

- 2) Align gang with gang tube and raise into position.

- 3) Replace U-bolts over gang tube and secure with lockwashers and nuts.

#### **Delta Rigid Hanger Gangs:**

The top straps have a tab on one side for mounting the scrapers. This tab should be to the rear when the gang is correctly positioned.

- 1) remove the two bolts and top strap from the hangers.

- 2) Position the gang with the hangers against the gang tube. Place the top straps over the hangers on top of the gang tube.

- 3) Replace the hardware and tighten.

#### **Spring Hanger Gangs:**

The scraper bracket located within the spring hanger should point to the rear when the gang is correctly positioned.

- 1) Remove the single bolt from each hanger and loosen U-bolt but **do not remove**.

- 2) Slide gang onto gang tube with thick plate on top and thin plate\* on bottom between gang tube and hanger. Replace bolt in hanger.

\*Note: Gangs with 1-1/2" axles do not have a thin plate on the hanger assembly.

### **Scrapers**

The scrapers bolt to the hangers so that the scraper blades point into the cupped side of the disc blades. With the exception of the inside rear and outside front blades, all of the disc blades get scrapers.

- 1) Lay each scraper bundle with the top leg of the scraper bar pointing down. With the scraper bundles positioned this way, stand on the scraper side of each bundle and note the direction the scrapers point. If the scrapers point to the LEFT, the bundle is a RIGHT HAND assembly and is used on a right front or left rear gang. If the scrapers point to the RIGHT, the bundle is a LEFT HAND assembly and is used on a left front or right rear gang.

- 2) Separate all of the scraper bundles as described in Step 1, and pair up each scraper bundle with a disc gang. Keep in mind that the inside rear blades do not get a scraper and the outside front blades do not get a scraper.

3) With all of the scraper bundles correctly positioned, bolt them to the disc gangs using the hardware included with each bundle. Slide the scrapers within the slotted holes so the blades nearly touch the disc blades. Tighten the hardware.

## **ADJUSTMENTS**

### **Wing Leveling**

The wings on your harrow will have the tendency to fold down in operation. Adjust the wings according to your soil conditions and preference. To adjust the wings, shorten the wheel lift connector to raise the position of the wing or lengthen it to lower the position of the wing. Several adjustments may be needed to obtain the desired results.

### **Front to Rear Leveling**

To level the harrow from front to rear, use the spring rods on the top tongue.

1) Loosen the top 1-3/8" nut so that no pressure is on the top spring when the harrow is down in operating position. Raise the harrow to transport position to allow easier adjustment of the bottom spring.

2) With the top spring loose, tighten the bottom spring to increase the plowing depth of the rear gangs. To decrease the cutting depth of the rear gangs, loosen the bottom spring by screwing down on the hex nut.

3) After the cut depth has been adjusted, lift the harrow to its transport position. Tighten the top spring by screwing down on the nut located above the spring until the harrow is approximately level.

### **Wing Float**

The wing can be adjusted to have more floating action in either the up or down direction. For more float in the down direction, screw the clevis on the wing cylinder in. Screw the clevis out for more float in the up direction. Remember that by adjusting for more float in one direction, you give up float in the opposite direction.

### **Eliminating Balk**

Balk is caused by having too much space between the inside iron disc blades.

1) Loosen the hardware holding the front gangs to the frame.

2) Slide the inside gangs inward until the butt plates on the inside gangs are 1/2" from touching. Tighten the inside gangs to the frame making sure they are centered on the main frame.

3) Adjust the other gangs in so that correct disc spacing is maintained between the gangs (8" or 9").

4) Tighten gangs to frame.

If this adjustment does not solve the problem, see about installing a balk breaker attachment.

### **Adjusting for Ridging and Furrowing**

If front to rear leveling does not eliminate the ridge or furrow in the center of the cut, the position of the rear gangs must be adjusted.

1) Loosen the hardware holding the rear gangs to the frame.

2) Move all of the rear gang assemblies out if the harrow is leaving a ridge. If the harrow is not filling up the furrow left by the center of the front gangs, move all of the gangs in toward the center of the harrow.

3) Make sure all gangs are moved the same distance in relation to the center. Maintain proper disc spacing between adjacent gangs (8" or 9").

4) Operating speed will affect these adjustments so make adjustments according to the desired operating speed.

### **Depth of Cut**

The depth of cut is controlled by the two transport lift cylinders or by using the depth bars.

1) To use the depth bars, slide the cuff on the depth bar back to increase operating depth. Be sure the cuffs are set at the same position. "Half hole" adjustment of the cuff is possible by turning it around and returning it to the same hole.

2) With the cuffs in the desired position, lower the harrow until the frame engages the cuffs.

Never locate the cuff in front of the bracket through which the bar slides.

## **WARNING**

Before working underneath, raise harrow to highest position, install transport locks, and block securely. Blocking up prevents harrow dropping from hydraulic leak down, hydraulic system failures, or mechanical component failures.

## **MAINTENANCE**

### **Tightening Disk Axles**

The disk axles are torqued at the factory and do not require further tightening before use. After the first few hours of operation, the gang components will "seat" themselves which tends to loosen the axles. After this initial run-in period, the disk axle should be checked and retorqued if necessary. Torque 1-1/8" axles to 500 ft-lbs and 1-1/2" axles to 1000 ft lbs.

To check the tightness of the gang axle, raise the harrow off the ground and strike each blade lightly with a hammer. If a flat sound is heard, the blade is loose and the gang axle must be retorqued. A ringing sound indicates the blade is tight.

After this check, the axles should not require tightening unless the axle nut is removed.

### **Wheel Hubs**

After initial use check wheel hubs for excessive play on spindle. If necessary, tighten bearing adjustment nut to eliminate lateral movement on spindle while still allowing hub rotation.

## **BEFORE OPERATION**

1) Tighten all loose hardware using the torque chart. Replace any missing hardware. On new harrows, all hardware must be rechecked after first few hours of operation as vibration will tend to loosen bolts.

2) Replace any bent or broken parts.

3) Perform lubrication on harrow as recommended. **SEE MAINTENANCE.**

4) Refer to your Tractor's Owner's Manual for recommended adjustments and weight distribution.

5) Inspect hydraulic lines and fittings for wear and leaks. Repair or replace if needed.

### **Preparing the Tractor**

• See Recommended Tractors in the Specification section.

• Consult tractor operator's manual for specific adjustment procedures, tire inflation, wheel spacing, and ballast requirement.

• Check hydraulic oil level. Fill, if necessary.

• Turn metering valves to fast position.

• If tractor is equipped with a 3-point quick coupler, raise 3-point hitch fully. Be sure rockshaft lever is set to keep quick-coupler up at all times.

• If not equipped with a 3-point quick coupler, secure lift links and top link so they do not swing into tractor tires, hitch, or onto hydraulic hoses.

• Place tractor drawbar in fixed centered down position, 16 to 20 inches from ground to top of drawbar. For 4 wheel drive tractors, leave one hole clearance each side of drawbar for **FIELD OPERATION ONLY.**

• Always pin drawbar in center position for **ALL** tractors when transporting harrow.

- Always use a safety hitch pin of the correct diameter. Make sure the hitch pin is locked in place with a safety type lock pin or other locking device.

#### Preparing the Disk Harrow

- Inflate all tires to recommended air pressure.
- Lubricate the harrow according to instructions in the lubrication section in this manual.
- Inspect for loose, missing, or damaged parts. Repair if necessary.
- Check all bolts for correct torque.
- Check the routing of all hydraulic hoses and wiring to prevent damage during operation.
- Check all safety equipment.
- **READ AND UNDERSTAND** the operating instructions in this manual.

#### ATTACHING

Your harrow is equipped with a reversible clevis that can be used with a single drawbar or one equipped with a hammerstrap hitch.

- With the tongue parallel to the ground in the operating position, position the clevis at the same height as the tractor drawbar.
- Attach the harrow to the tractor using a suitable high strength hitch pin and secure with a hairpin clip.
- Connect hydraulic lines to tractor. (Lines running from tongue hydraulic header to tractor are not supplied.)

#### OPERATION

##### First Time Out

1) Start tractor engine to perform hydraulic system check.

#### **WARNING**

**Perform all tractor operations only while seated in the tractor seat. Do not stand beside tractor.**

- 2) Watch fittings for leaks. If leaks are noticed, shut off tractor, relieve pressure from hydraulic lines, and make repairs before proceeding.
- 3) Check movement of wheel lift to be sure there is no interference.
- 4) Move wheel lift through full range of motion several times to purge air from system.
- 5) Slowly lift each wing to transport position.

#### **WARNING**

**Be sure all bystanders are clear before lifting wings. Do not walk under raised wings for any reason.**

- 6) Again check for leaks and make necessary repairs before proceeding.
- 7) Lift and lower wings several times to purge air from lines.
- 8) After hydraulic system is fully charged, check the level of the tractor's fluid reservoir and refill if necessary.

#### **WARNING**

**Do not use bare hand to check for leaks. Hydraulic fluid under high pressure can penetrate skin and cause poisoning.**

## **TRANSPORTING**

- 1) Lift harrow as high as possible. Install cylinder locks over wheel lift cylinder rods.
- 2) Fold wings up into wing stops and pin.
- 3) Level harrow front to rear using top spring on spring rods. See "Front to Rear" Leveling under **Adjustments**.
- 4) Transport at no more than 20 MPH. Use caution on rough terrain.
- 5) Check local laws governing transport of farm equipment on public roads.
- 6) Use caution and be aware of oncoming traffic and roadside obstructions.
- 7) Always use a slow moving vehicle (SMV) emblem. Mount it to the bracket on the rear cross frame.
- 8) **DO NOT** transport on public roads at night.
- 9) **BEWARE** of overhead wires and **KNOW** the transport height and width of your harrow. Avoid contact as this can cause serious injury or death. See Specification Section.

## **Removing Harrow from Tractor**

Select a level well drained area to park harrow.

Stop engine, set parking brake, and remove key before dismounting tractor.

Install wheel chocks on harrow. Remove hydraulic pressure from lines and disconnect hydraulic quick couplers. Install parking jack on tongue and raise tongue to remove pressure from tractor drawbar. Disconnect safety tow chain from tractor and remove drawbar pin.

Do not stand on or straddle a tongue when unhitching.

Disconnect harrow from tractor and carefully drive tractor away from harrow.

## **Lubrication Schedule**

- 1) Apply grease to the following lubrication points before each use. Be sure to clean grease fittings before applying grease.
  - Wing hinges
  - Spring rods
  - Disc gang bearings
  - Wheel lift bearings
- 2) Clean wheel hubs at the end of each season. Repack with grease and reassemble. Be sure to tighten bearing adjustment nut so hub turns freely without lateral movement on spindle.

## **STORAGE**

- 1) Store unit under shelter from weather.
- 2) With wings locked in storage position, lower harrow to relieve weight from transport cylinders.
- 3) Support tongue with jack to relieve weight from drawbar.
- 4) Relieve pressure from hydraulic lines before disconnecting from tractor.
- 5) For periods of long storage, coat disk blades and other soil engaging surfaces with oil to prevent rusting.

## **Balk Breaker Assembly (Optional)**

The balk breaker is used to remove ridges between gangs.

- Install balk breaker using 3/4" hardware provided between the front gang angles.
- Adjust the height to break up the untilled soil.

<b>TROUBLESHOOTING</b>		
<b>Problem</b>	<b>Cause</b>	<b>Possible Solution</b>
<b>Tractor Wheel Slippage</b>	<b>Disk Too Deep</b>	<b>Add Wheel Weights or Fluid</b>
		<b>(See Tractor Operator's Manual)</b>
		<b>Reduce Harrow Operating Depth</b>
<b>Leaving Ridge in Center</b>	<b>Operating Speed Too Fast</b>	<b>Reduce Speed</b>
	<b>Rear Gangs Cutting Too Deep</b>	<b>Adjust Front to Rear Level</b>
<b>Front or Rear Gangs Cutting Too Deep</b>	<b>Harrow Not Level</b>	<b>Adjust Level With Spring Rods</b>
		<b>(See Adjustments)</b>
<b>Leaving Furrow in Center</b>	<b>Harrow Not Level</b>	<b>Adjust Level With Spring Rods</b>
		<b>(See Adjustments)</b>
<b>Gangs or Discs Clogging</b>	<b>Wet Field</b>	<b>Allow Field to Dry</b>
	<b>Scrapers Not Cleaning</b>	<b>Adjust Scrapers in Closer to Blades</b>
<b>Harrow Not Level in Transport</b>	<b>Spring Rods Not Adjusted Properly</b>	<b>Adjust Top Spring Nut</b>
<b>Wing Sections Cutting Too Deep</b>	<b>Not Enough Support From Wheels</b>	<b>Do Not Allow Wheels to Float - Adjust Depth Bar Cuff In</b>
		<b>Adjust Wing Wheel to Provide More Support of Wing</b>

<b>MISCELLANEOUS HARDWARE BY SIZE</b>				
<b>Size</b>	<b>Part Number By Item</b>			
	<b>WASHER/LOCK</b>	<b>WASHER/FLAT</b>	<b>NUT/HEX</b>	<b>NUT/HEX LOCK</b>
<b>1/4"</b>	<b>303951</b>	<b>-</b>	<b>304003</b>	<b>-</b>
<b>5/16"</b>	<b>303952</b>	<b>303968</b>	<b>304004</b>	<b>-</b>
<b>3/8"</b>	<b>303953</b>	<b>303969</b>	<b>304005</b>	<b>304018</b>
<b>7/16"</b>	<b>303954</b>	<b>303970</b>	<b>304006</b>	<b>304019</b>
<b>1/2"</b>	<b>303955</b>	<b>303971</b>	<b>304007</b>	<b>304020</b>
<b>5/8"</b>	<b>303956</b>	<b>303972</b>	<b>304008</b>	<b>304021</b>
<b>3/4"</b>	<b>303957</b>	<b>303973</b>	<b>304009</b>	<b>304022</b>
<b>7/8"</b>	<b>303958</b>	<b>303974</b>	<b>304010</b>	<b>304023</b>
<b>1"</b>	<b>303959</b>	<b>303975</b>	<b>304011</b>	<b>304024</b>
<b>1-1/8"</b>	<b>303960</b>	<b>303976</b>	<b>304012</b>	<b>304025</b>
<b>1-1/4"</b>	<b>303961</b>	<b>303977</b>	<b>304013</b>	<b>304026</b>

**THIS PAGE INTENTIONALLY LEFT BLANK**

**Disc & Bearing Configuration  
for  
Harrows with 8" Front and 8" Rear Spacing**

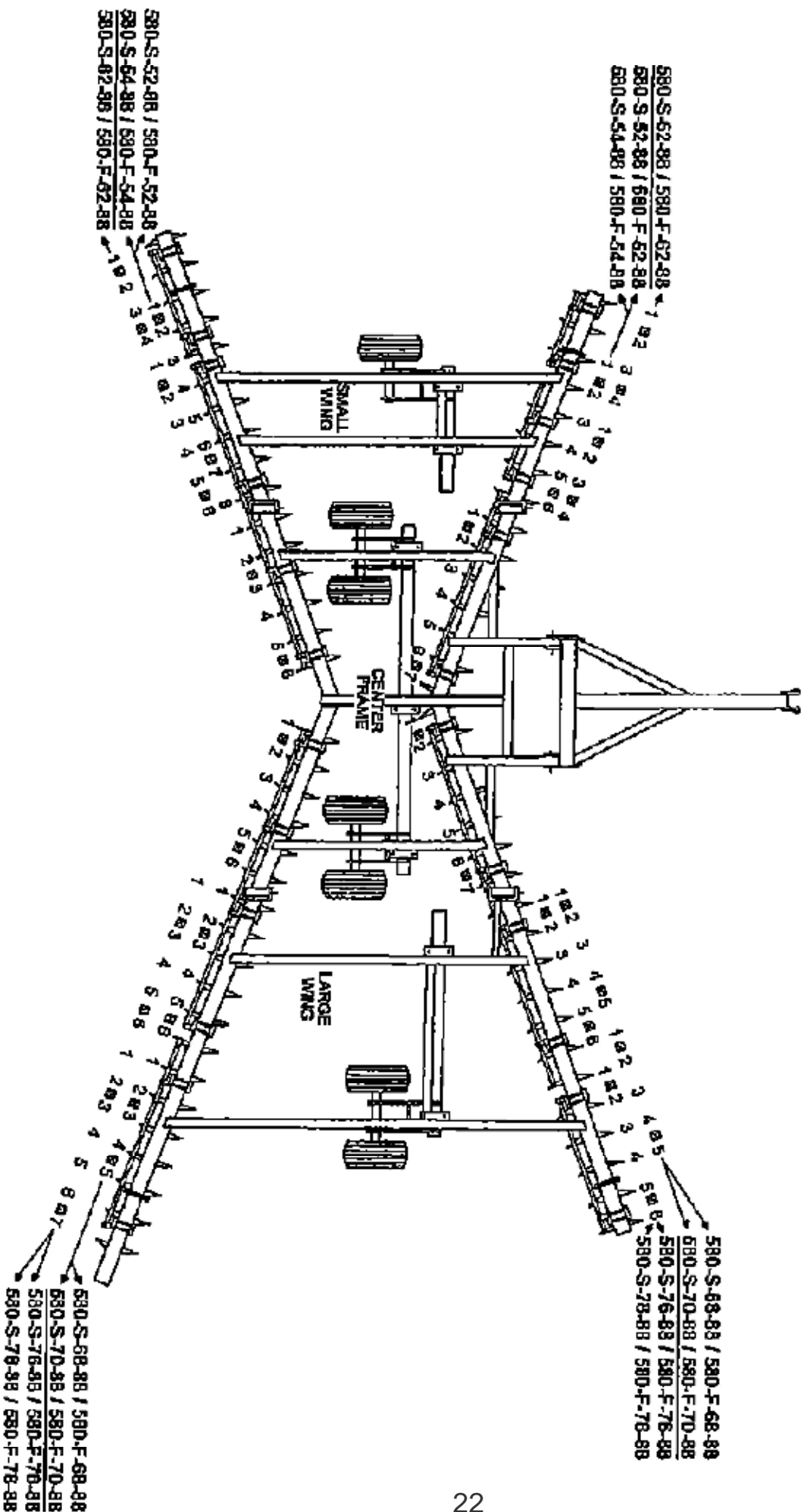

Models 580-S Have Rigid Brg. Hangers  
 Models 580-F Have Spring Brg. Hangers







**Disc & Bearing Configuration**  
**for**  
**Harrows with 8" Front and 8" Rear Spacing**  
**for Harrows with DELTA style axles**

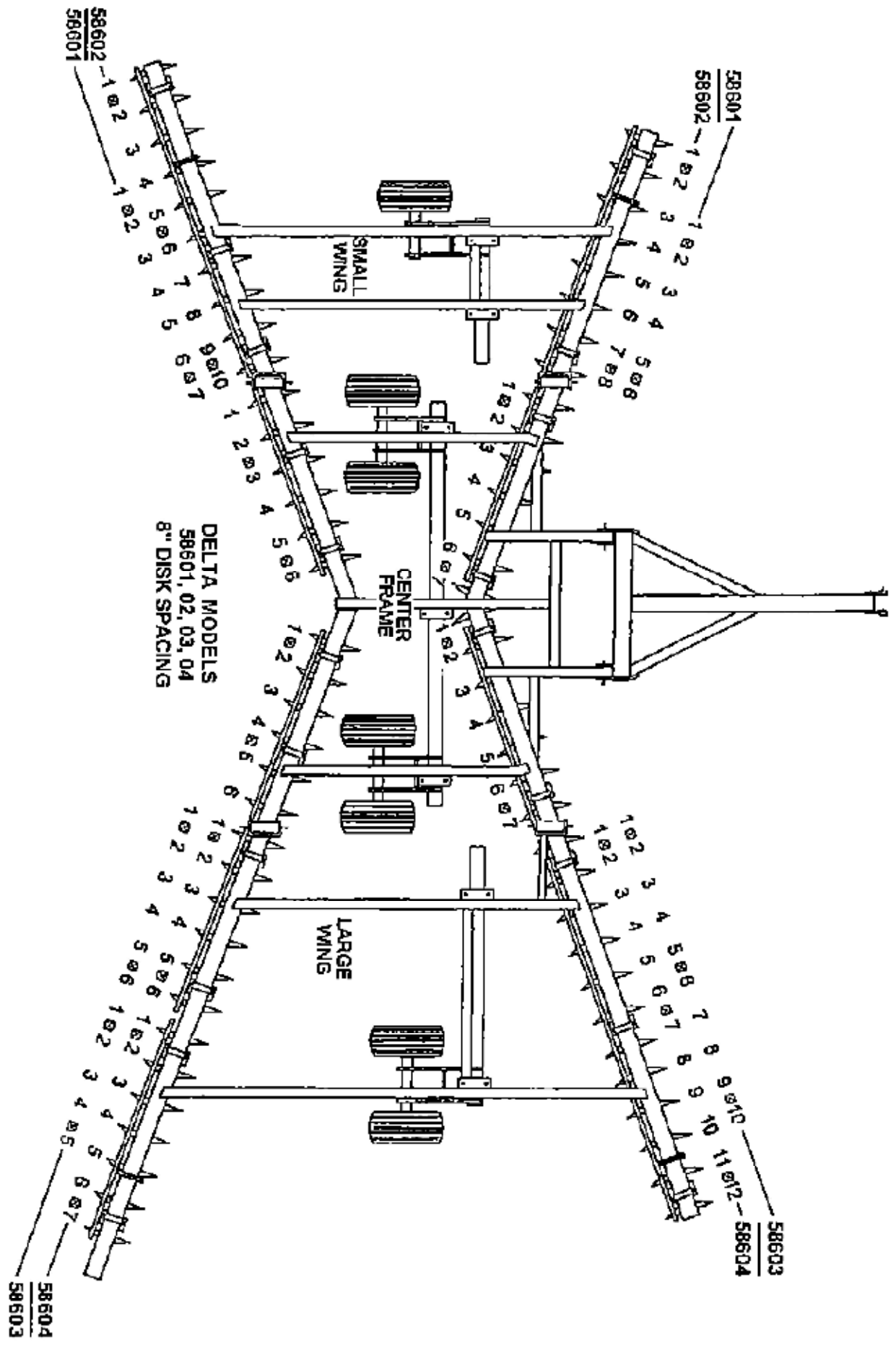

Disc & Bearing Configuration  
for  
Harrow with 9" Front and 9" Rear Spacing  
for Harrows with DELTA style axles

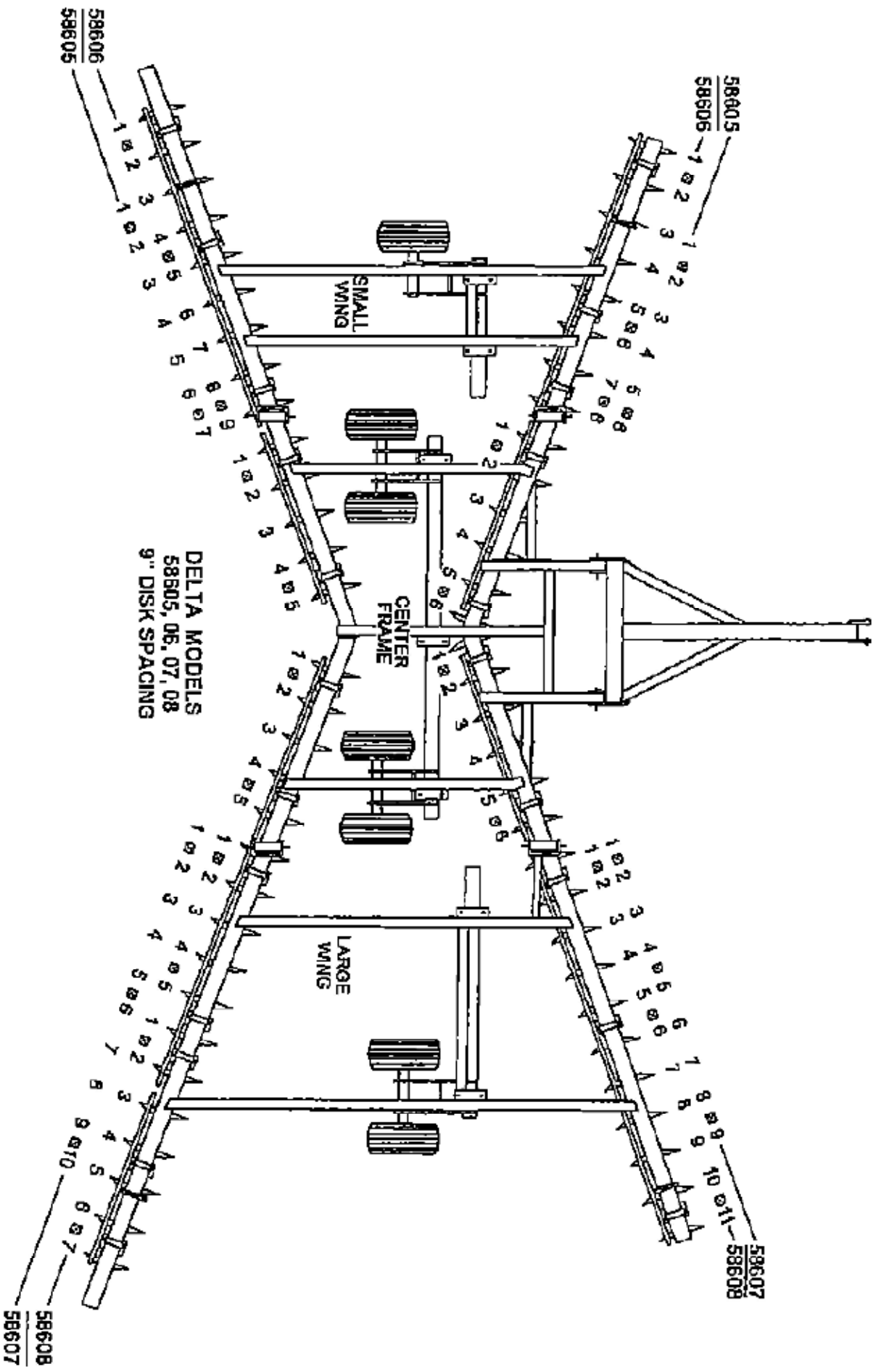

Disc & Bearing Configuration  
for  
Harrow with 9" Front and 8" Rear Spacing  
for Harrows with DELTA style axles

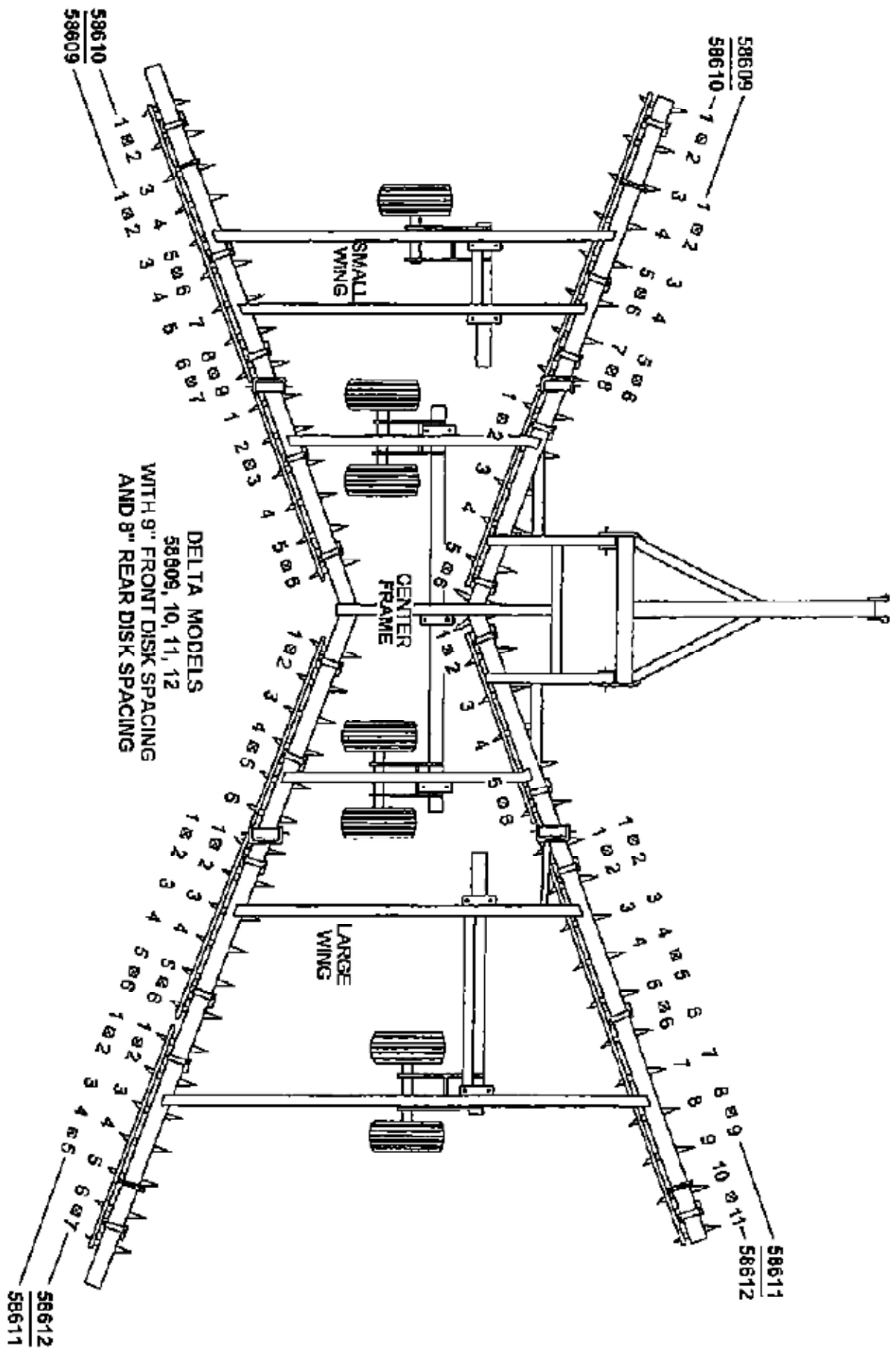

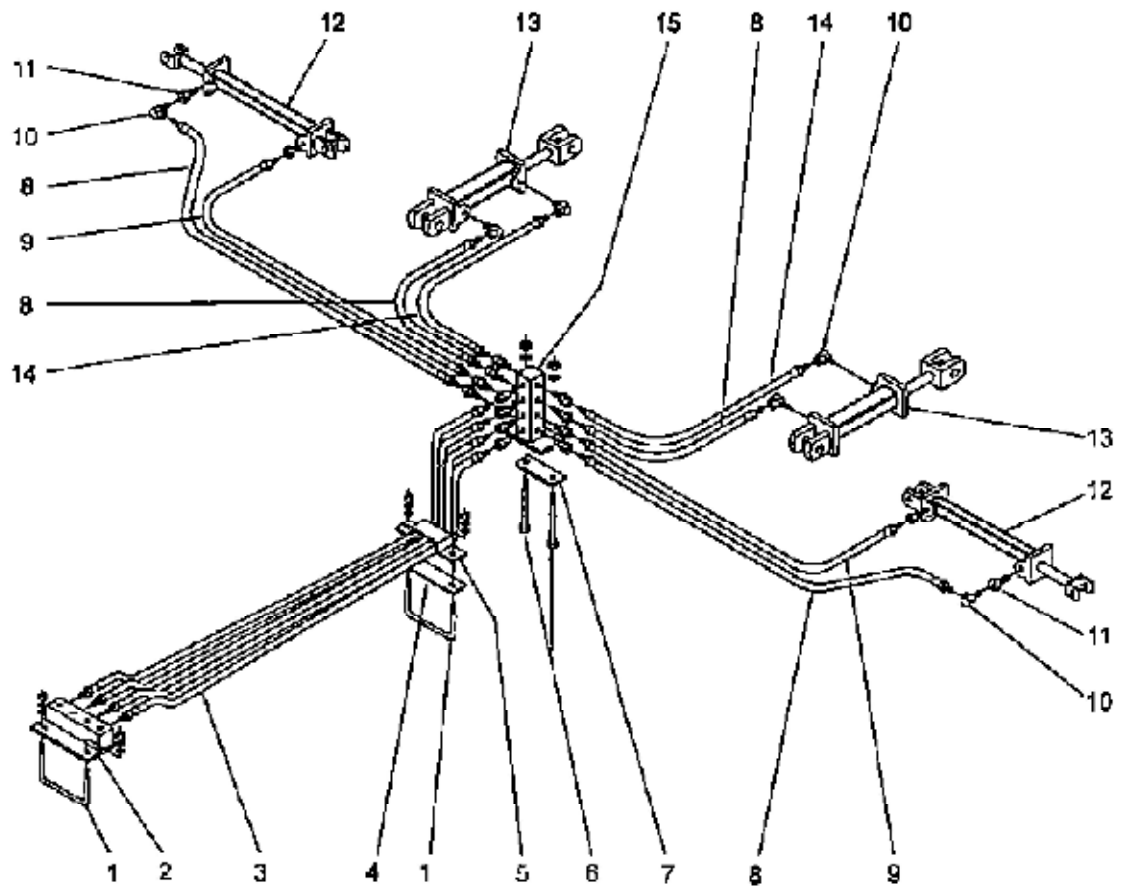
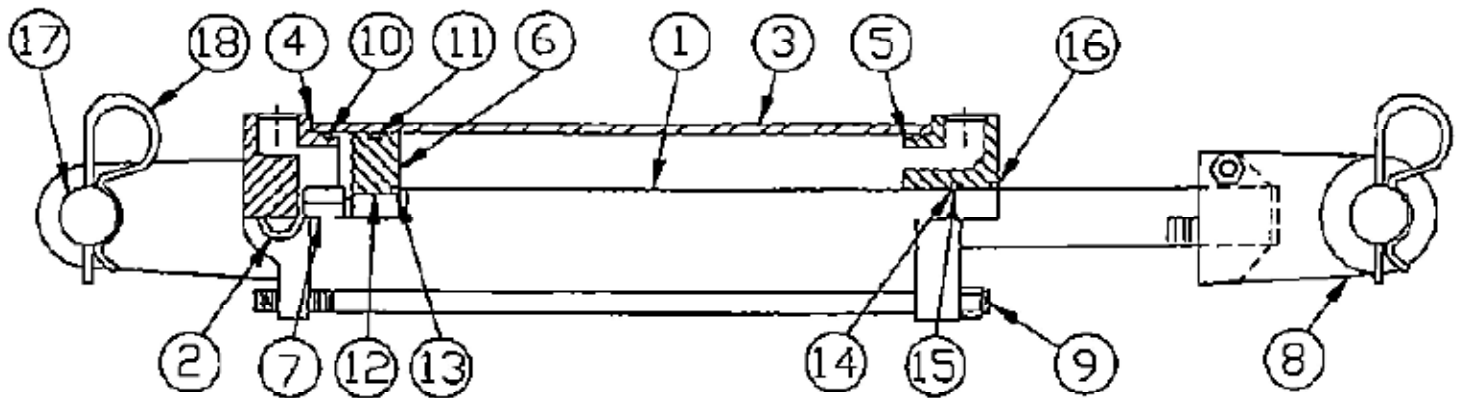

FIGURE 8 - HYDRAULIC COMPONENTS

ITEM	PART #	DESCRIPTION	QTY
1	209090	U-BOLT 5/8"	2
	303956	WASHER/LOCK 5/8"	4
	304008	NUT/HEX 5/8" NC	4
2	209179	HYD HEADER ASSY	1
3	209227	HYDRAULIC HOSE ASSY 88"	4
4	209174	HOSE HOLDER BASE	1
5	209173	HYD HOSE HOLDER	1
6	303667	HHCS 5/8" X 6-1/2"	2
	303956	WASHER/LOCK 5/8"	2
	304008	NUT/HEX 5/8" NC	2
7	209178	STRAP - CONNECTOR	1
8	209225	HYDRAULIC HOSE ASSY 38"	4
9	209224	HYDRAULIC HOSE ASSY 24"	2
10	207982	ST-EL 1/2" X 90°	8
11	208569	RESTRICTOR - FLOW	2
12	207987	CYL/HYD 4" X 24"	2
13	209134	CYL/HYD 4" X 8"	2
14	209226	HYDRAULIC HOSE ASY 46"	2
15	209175	HYD MANIFOLD ASSEMBLY	1



**FIGURE 15 HYDRAULIC CYLINDER COMPONENTS**

item	part no. 4x8	part no. 4x24	description	qty.
1	209230	208844	piston rod	1
2	208602	208602	pipe plug	2
3	209231	208845	tube	1
4	208846	208846	butt	1
5	208847	208847	gland	1
6	208848	208848	piston	1
7	208849	208849	lock nut	1
8	208850	208850	clevis assembly	1
9	209232	208851	tie rod	4
10	**	**	O-ring	2
11	**	**	O-ring	1
12	**	**	Bu-washer	2
13	**	**	O-ring	1
14	**	**	O-ring	1
15	**	**	Bu-washer	1
16	**	**	wiper	1
17	208859	208859	clevis pin	2
18	208617	208617	half pin clip	4
19	208569	208569	flow restrictor	2
**	208860	208860	seal kit (incl. 10-16)	1
	209134	207987	cylinder complete	-

FIGURE 9 - FRAME & TONGUE COMPONENTS

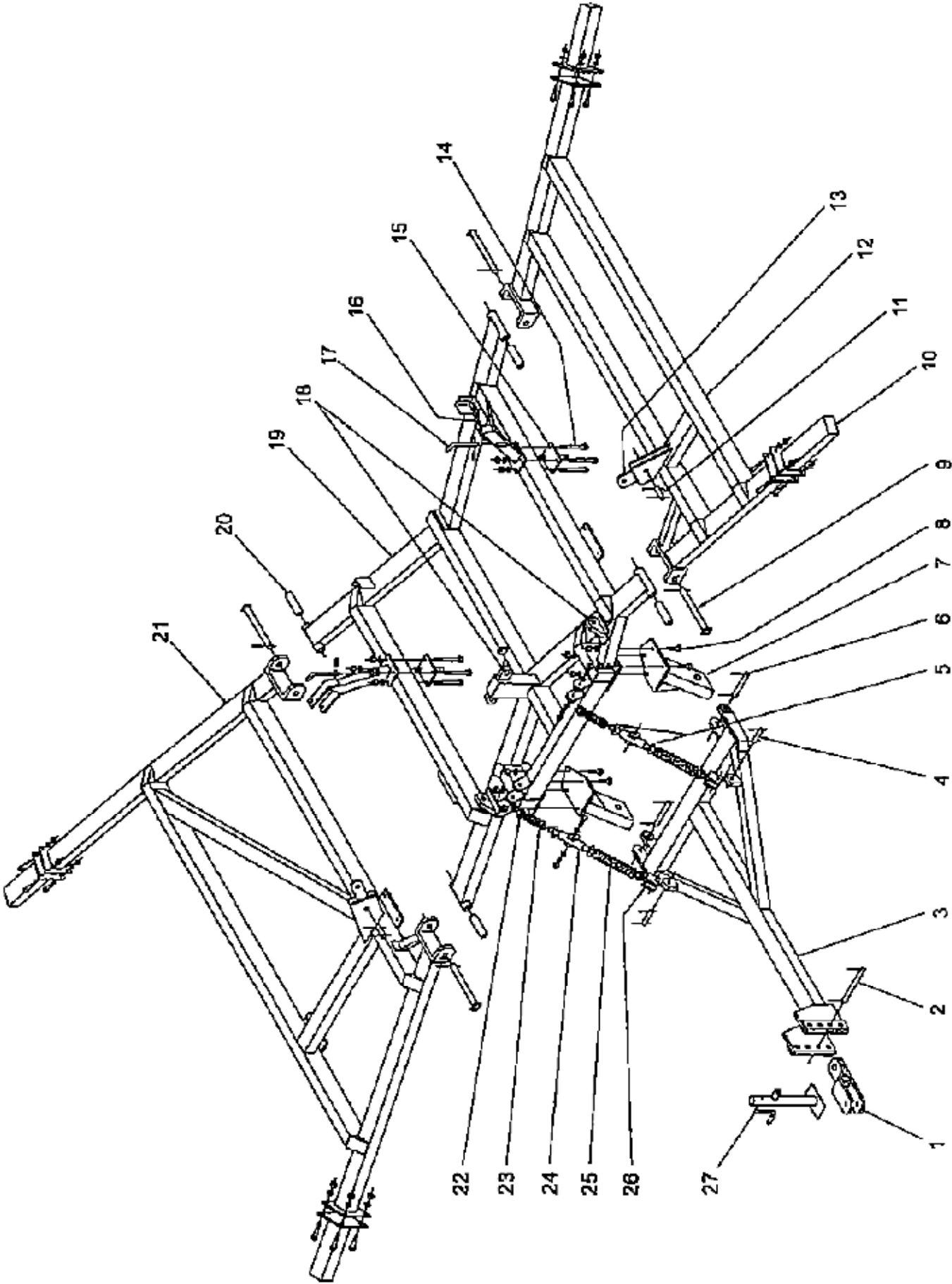



**FRAME & TONGUE COMPONENTS (Refer to Figure 9)**

Item	Part #	Description	Qty
1	209013	SINGLE OR DOUBLE DRAWBAR CLEVIS	1
2	209186	CLEVIS PIN 1-3/8" X 9"	1
	304161	PIN/COTTER 3/8" X 2"	2
3	209531	TONGUE ASSEMBLY	1
4	209100	PIN 7/8" X 3-3/5"	2
	304137	PIN/COTTER 5/16" X 1-1/2"	4
5	205163	WASHER/FLAT SPECIAL 1-3/8" X 2-1/4" X 1/16" THK	4
6	209125	PIN/TONGUE HINGE 1-3/8" X 8"	2
	304151	PIN/COTTER 3/8" X 2"	3
7	810263	LEFT TONGUE CONN. ASSY. AFTER 10-94	1
	810264	RIGHT TONGUE CONN. ASSY. AFTER 10-94	1
	209200	LEFT TONGUE CONN. ASSY. PRIOR TO 10-94	1
	209199	RIGHT TONGUE CONN. ASSY. PRIOR TO 10-94	1
8	303728	HHCS 7/8" X 2-1/2"	8
9	209128	PIN/WING HINGE	4
	304151	PIN/COTTER 3/8" X 2"	8
10	209018	FRAME EXTENSION (ON SOME MODELS)	4
	303700	HHCS 3/4" X 2-1/4"	16
11	209126	PIN/WING FLOAT 1" X 3-1/2"	2
	304151	PIN/COTTER 3/8" X 2"	4
12	211280	LEFT WING FRAME (SMALL FRAME MODELS)	1
	211282	LEFT WING FRAME (LARGE FRAME MODELS)	1
13	209044	WING LIFT ARM	2
	208863	TENSION BUSHING IN WING LIFT ARM	2
14	303690	HHCS 5/8" X 8" GR5	4 per wing stop
15	211259	PLATE 1/2" X 5" X 6"	1 per wing stop
16	211258	WING STOP ASSEMBLY	2-sm frame 4-lg frame
17	211272	PIN/WING LATCH 5/8" X 10"	1 per wing stop
	304244	PIN/HAIR PIN COTTER 3/16" X 3-1/4"	1 per wing stop
18	208863	TENSION BUSHING IN CYLINDER MOUNTS	4
19	813942	CENTER FRAME AFTER 10-94	1
	211256	CENTER FRAME PRIOR TO 10-94	1
20	209045	WING HINGE BUSHING	4
21	211279	RIGHT WING FRAME (SMALL FRAME MODELS)	1
	211281	RIGHT WING FRAME (LARGE FRAME MODELS)	1
22	304053	NUT/HEX HEAVY 1-3/8" NC	4
23	208612	SPRING/COMPRESSION 2-7/16" OD X 7-5/8"	2
24	209742	SPRING ROD SLIDE ASSEMBLY	2
	304194	ALEMITE	2
	209748	BOLT/SHOULDER 7/8" X 1-1/2"	4
25	209148	SPRING/COMPRESSION 2-7/8" OD X 14"	2
26	210935	SPRING ROD	2
27	808026	JACK 3000#	1

FIGURE 10 - TRANSPORT LIFT COMPONENTS

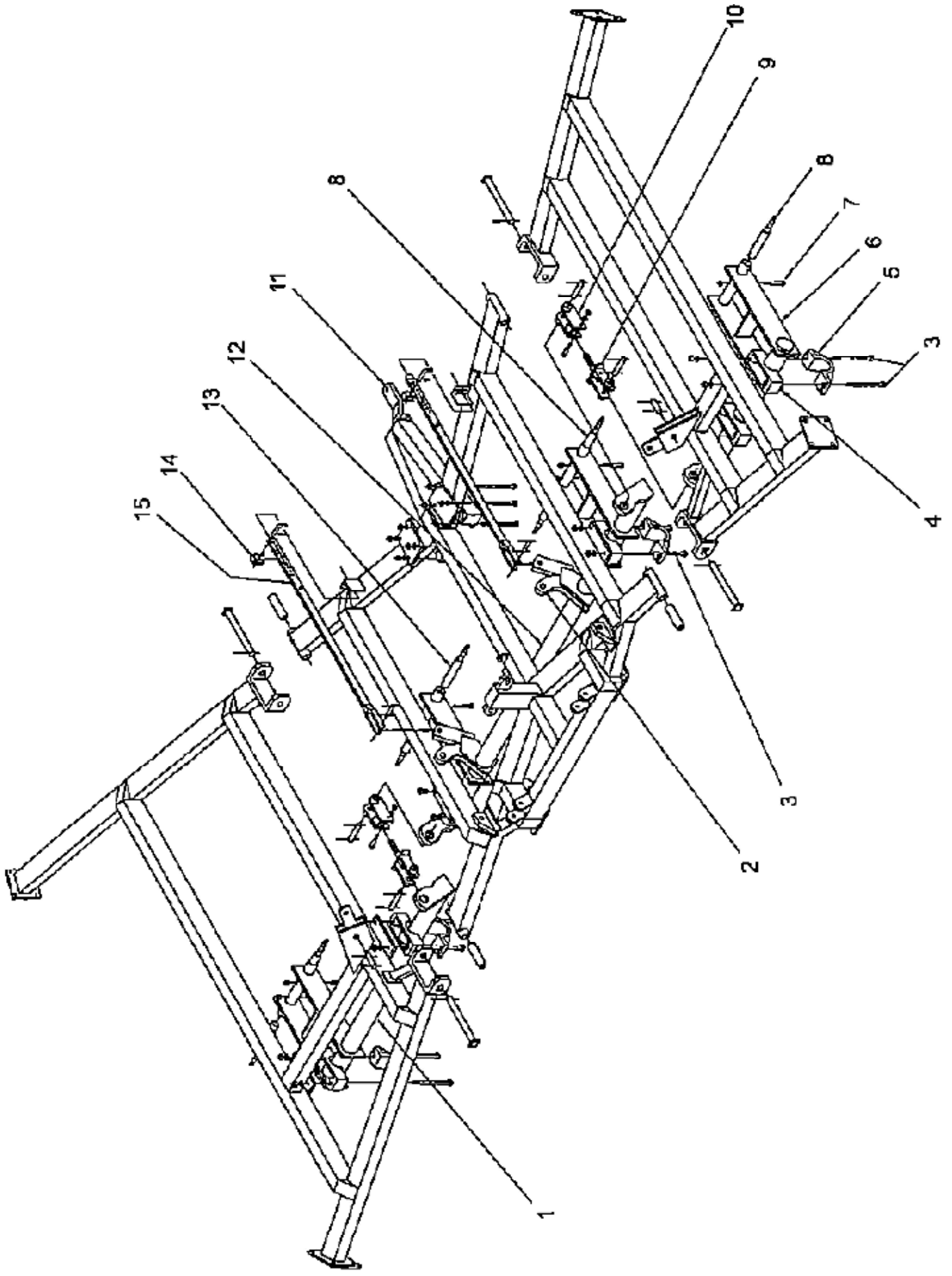

<b>TRANSPORT LIFT COMPONENTS (Refer to Figure 10)</b>			
<b>Item</b>	<b>Part #</b>	<b>Description</b>	<b>Qty</b>
1	211245	RIGHT WHEEL AXLE (SMALL FRAME MODELS)	1
	211248	RIGHT WHEEL AXLE (LARGE FRAME MODELS)	1
	809159	RIGHT WHEEL AXLE (FOR MODELS 58606, 58706, 58506, 58122, 58522)	1
2	211273	HYDRAULIC CYLINDER BRACKET	2
	208863	BUSHING/TENSION 1-1/4" OD X 1" ID	2
3	303736	HHCS 7/8" X 6"	8
4	209235	WHEEL AXLE BEARING TOP HALF	4
5	209236	WHEEL AXLE BEARING BOTTOM HALF	4
6	211246	LEFT WHEEL AXLE (SMALL FRAME MODELS)	1
	211249	LEFT WHEEL AXLE (LARGE FRAME MODELS)	1
	809158	LEFT WHEEL AXLE (FOR MODELS 58606, 58706, 58506, 58122, 58522)	1
7	303657	HHCS 1/2" X 3"	8
8	210685	SPINDLE (WING AXLES AND OUTSIDE MAIN FRAME)	4-sm frame 6-lg frame
	809149	SPINDLE (FOR MODELS 58606, 58706, 58506, 58122, 58522)	4
9	808793	MALE SWIVEL ASSEMBLY	2
	304194	ALEMITE	2
	808786	PIN/SWIVEL - 1-1/8 OD x 5-1/2" LONG	1
	304137	PIN/COTTER 5/16 x 3	2
10	808792	FEMALE SWIVEL ASSEMBLY	2
	208936	BUSHING/TENSION 1-3/8" OD X 1-1/8" ID	2
	808786	PIN/SWIVEL - 1-1/8 OD x 5-1/2" LONG	1
	304137	PIN/COTTER 5/16 x 3	2
	303682	HHCS 5/8" X 4"	2
11	211161	OPTIONAL TOW HITCH WELDMENT	1
	211166	PLATE - TOW HITCH	2
	303716	HHCS 3/4" X 9-1/2"	8
299151	<b>TOW HITCH ATTACHMENT</b>		
12	801133	MAIN FRAME WHEEL LIFT	1
13	211284	SPINDLE (INSIDE MAIN FRAME ONLY)	2
14	204683	DEPTH CONTROL CUFF	2
	209938	PIN/DEPTH BAR BENT 5/8" DIA.	2
	304244	PIN/HAIRPIN COTTER 3/16" X 3-1/4"	2
15	211288	DEPTH CONTROL BAR	2
	208092	PIN/CLEVIS 1-1/8" X 3-3/8"	2
	304151	PIN/COTTER 3/8" X 2"	4

# STANDARD RIGID & SPRING BEARING HANGER COMPONENTS

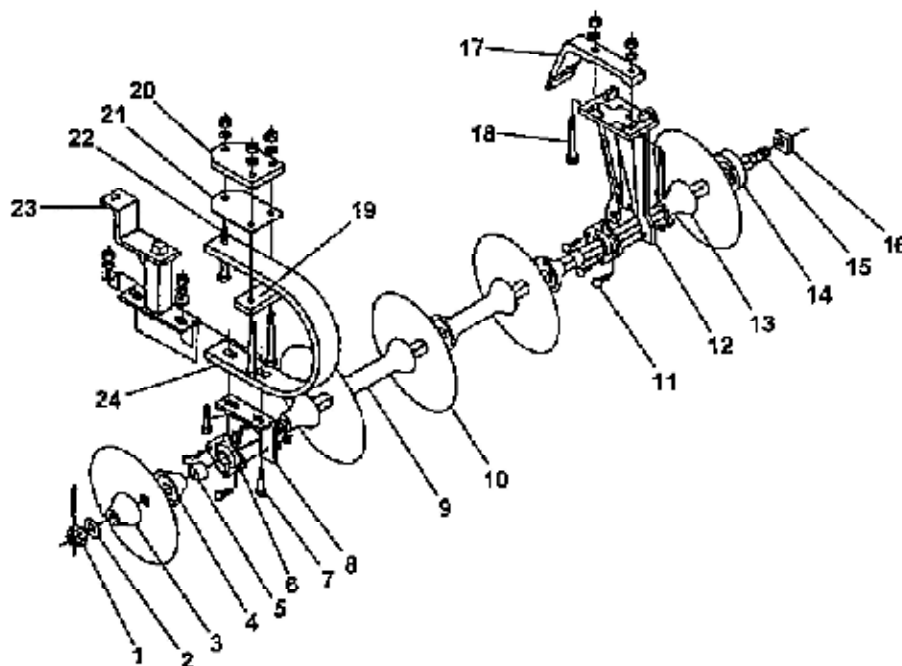
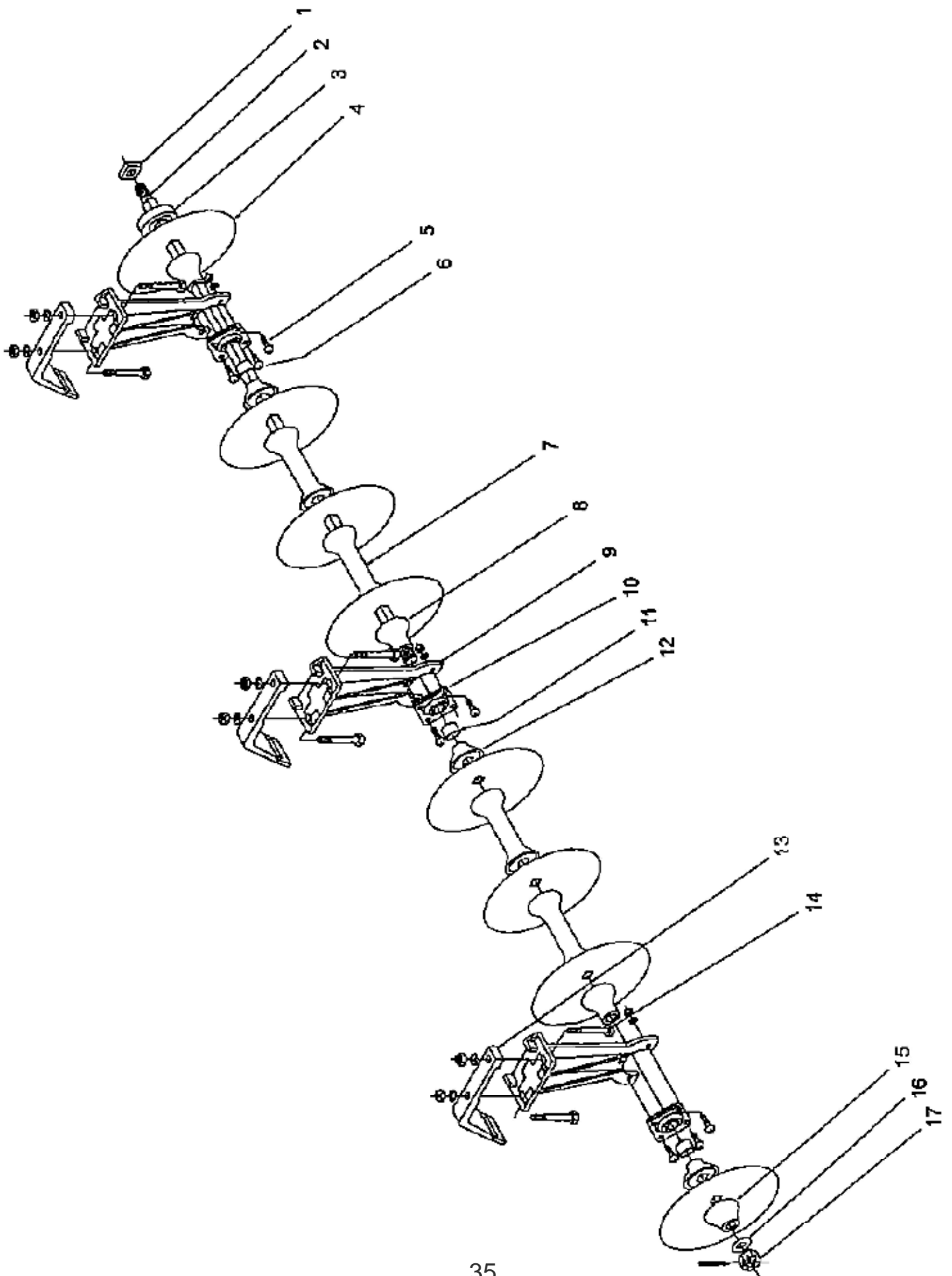

FIGURE 11 - DISC GANG COMPONENTS

Item	Part #	Description
1	304039	SLOTTED HEX NUT 1-1/8"
	304111	COTTER PIN 3/16" X 2"
2	303976	FLATWASHER 1-1/8"
3	204704	END WASHER
4	205486	CONCAVE SPACER 2-13/16" Long
5	807110	SPACER 1-5/16" Long for 9" Sp.
	807111	SPACER 5/16" Long for 8" Spacing
6	811197	BEARING DHU 1-1/8" S209
7	303680	HHCS 5/8" X 3" - NC Gr.5
	303956	5/8" LOCK WASHER
	303972	5/8" FLAT WASHER
	304008	5/8" HEX NUT - NC
8	808755	BRG. BRACKET for Spring Hanger
9	207339	DOUBLE END SPACER for 8" Sp.
	207344	DOUBLE END SPACER for 9" Sp.
10	---	DISC BLADES SEE Page 37
11	303859	CARRIAGE BOLT 1/2 X 1-1/2" Gr.5
	303955	1/2" LOCK WASHER
	304007	1/2" HEX NUT - NC
12	807873	RIGID BRG. HANGER
13	205489	CONVEX SPACER 3-5/16" Long
14	206613	BUTT PLATE

Item	Part #	Description
15	207097	AXLE 4-D - 8" Sp. 1-1/8" X 29"
	207420	AXLE 5-D - 8" Sp. 1-1/8" X 37"
	208359	AXLE 6-D - 8" Sp. 1-1/8" X 45"
	209360	AXLE 7-D - 8" Sp. 1-1/8" X 53"
	206626	AXLE 4-D - 9" Sp. 1-1/8" X 32"
	206627	AXLE 5-D - 9" Sp. 1-1/8" X 41"
	206618	AXLE 6-D - 9" Sp. 1-1/8" X 50.3"
208131	AXLE 7-D - 9" Sp. 1-1/8" X 59"	
16	208931	SQUARE NUT 1-1/8" - NC
17	807874	TOP STRAP for Rigid Hanger
18	303708	HHCS 3/4" X 5-1/2" - NC Gr.5
	303957	3/4" LOCK WASHER
	304009	3/4" HEX NUT - NC
19	813106	STRAP
	303711	HHCS 3/4" X 7" - NC Gr.5
	303957	3/4" LOCK WASHER
	304009	3/4" HEX NUT
20	207823	TOP PLATE
21	208468	LOWER PLATE
22	303709	HHCS 3/4" X 6" - NC Gr.5
	303957	3/4" LOCK WASHER
	304009	3/4" HEX NUT
23	808309	SRAPER BAR BRKT. Spring Hgr.
24	207664	SPRING BEARING HANGER

FIGURE 13 - RIGID DELTA GANG COMPONENTS



**RIGID DELTA GANG COMPONENTS (Refer to Figure 13)**

Item	Part #	Description
1	208931	NUT/SQUARE 1-1/8"
2	207097	AXLE-BI-THRDED- 4 D- 8" SP 29"
	207420	AXLE-BI-THRDED- 5 D- 8" SP 37"
	209359	AXLE-BI-THRDED- 6 D- 8" SP 45"
	209360	AXLE-BI-THRDED-7 D- 8" SP 53"
	807120	AXLE-BI-THRDED-8 D- 8" SP 61-1/4"
	807122	AXLE-BI-THRDED-9 D- 8" SP 69-1/4"
	807123	AXLE-BI-THRDED- 10 D- 8" SP 77-1/4"
	807125	AXLE-BI-THRDED- 12 D- 8" SP 93-1/4"
	206626	AXLE-BI-THRDED- 4 D- 9" SP 32"
	206627	AXLE-BI-THRDED- 5 D- 9" SP 41"
	206618	AXLE-BI-THRDED- 6 D- 9" SP 50-5/16"
	208131	AXLE-BI-THRDED- 7 D- 9" SP 59"
	807121	AXLE-BI-THRDED- 8 D- 9" SP 68-1/4"
	807123	AXLE-BI-THRDED- 9 D- 9" SP 77-1/4"
	807124	AXLE-BI-THRDED- 10 D- 9" SP 86-1/4"
	807126	AXLE-BI-THRDED- 11 D- 9" SP 95-1/4"
3	206613	PLATE/BUTT
4	TABLE 1 pg 37	DISC BLADE
5	303859	BOLT/CARR 1/2" X 1-1/2"
6	303857	BOLT/CARR 1/2" X 1"
7	207339	SPACER/FULL 8" SP
	207344	SPACER/FULL 9" SP
8	205489	SPACER/CONVEX HALF
9	807873	HANGER CASTING
10	811197A	BEARING DHU 1-1/8" S209
11	807111	BUSHING/SPACER 5/16" LONG 8" SP
	807110	BUSHING/SPACER 1-5/16" LONG 9" SP
12	205486	SPACER/CONCAVE HALF
13	807874	TOP STRAP CASTING
14	303708	HHCS 3/4" X 5-1/2" HH BOLT
15	204704	WASHER/END
16	303976	WASHER/FLAT 1-1/8"
17	304039	NUT/HEX SLOTTED 1-1/8"

## TABLE 1 DISC BLADES

Part #	Description
208439	16" Round w/1-1/8" Sq. Hole
205003	18" Round w/1-1/8" Sq. Hole
204004	20" Round w/1-1/8" Sq. Hole
205020	22" Round w/1-1/8" Sq. Hole
208440	16" Cut Out w/1-1/8" Sq. Hole
205002	18" Cut Out w/1-1/8" Sq. Hole
204003	20" Cut Out w/1-1/8" Sq. Hole
205005	22" Cut Out w/1-1/8" Sq. Hole

### INSTRUCTIONS FOR ORDERING DISC BLADES

---

**When ordering blades, remember that the outside rear blades get two "taper" blades each and the outside front gangs get one "taper" blade each. Blades are tapered in 2" diameter increments.**

- 1) **Determine the total number of blades for the unit regardless of size.**
- 2) **For the main disc size, order (6) LESS than the total number found in step 1.**
- 3) **Order four (4) blades 2" smaller in diameter than the main size. These are taper blades for the outside front and rear gangs.**
- 4) **Order two (2) blades 4" smaller in diameter than the main disc size. These are outside taper blades for rear gangs.**

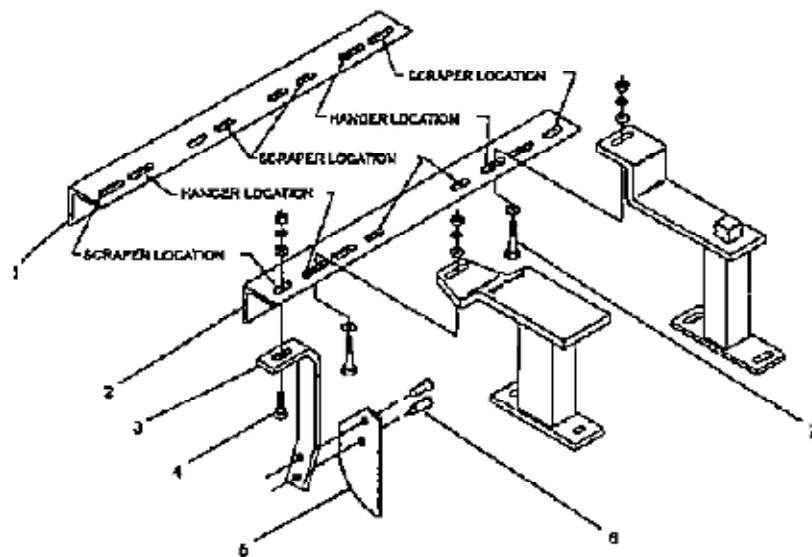

FIGURE 15 - SCRAPER COMPONENTS STANDARD MODELS

Item	Part #	Description
1	SEE TABLE 3 BELOW	SCRAPER BAR
2	SEE TABLE 3 BELOW	SCRAPER BAR
3	807096	L.H. HANDLE (USED ON LEFT FRONT OR RIGHT REAR GANG)
	807097	R.H. HANDLE (USED ON RIGHT FRONT OR LEFT REAR GANG)
4	303859	BOLT/GARR 1/2" X 1-1/2"
5	805000	SCRAPER BLADE
6	804999	SHOULDER RIVET
7	303853	HHCS 1/2" X 2
	807098	L.H. SCRAPER (INCL. 3,5,&6) (USED ON LEFT FRONT OR RIGHT RR GANG)
	807099	R.H. SCRAPER (INCL. 3,5,&6) (USED ON RIGHT FRONT OR LEFT RR GANG)

TABLE 3 SCRAPER BAR LISTING (#1 & 2 Figure 16)

Part #	Disc Gang Used On	Length (Inches)
805007	4 DISC 4 SCRAPER 8" DISC SPACING	27
805008	5 DISC 5 SCRAPER 8" DISC SPACING	35
805009	6 DISC 6 SCRAPER 8" DISC SPACING	43
805010	7 DISC 7 SCRAPER 8" DISC SPACING	51
804996	8 DISC 8 SCRAPER 8" DISC SPACING	59
805011	4 DISC 3 SCRAPER 8" DISC SPACING	23
805012	5 DISC 4 SCRAPER 8" DISC SPACING	31
805013	6 DISC 5 SCRAPER 8" DISC SPACING	39
805014	3 DISC 3 SCRAPER 9" DISC SPACING	21
805015	4 DISC 4 SCRAPER 9" DISC SPACING	30
805016	5 DISC 5 SCRAPER 9" DISC SPACING	39
805017	6 DISC 6 SCRAPER 9" DISC SPACING	48
805018	4 DISC 3 SCRAPER 9" DISC SPACING	24-3/4
805019	5 DISC 4 SCRAPER 9" DISC SPACING	33-3/4
805020	6 DISC 5 SCRAPER 8" DISC SPACING	42-3/4
805021	7 DISC 6 SCRAPER 9" DISC SPACING	51-3/4



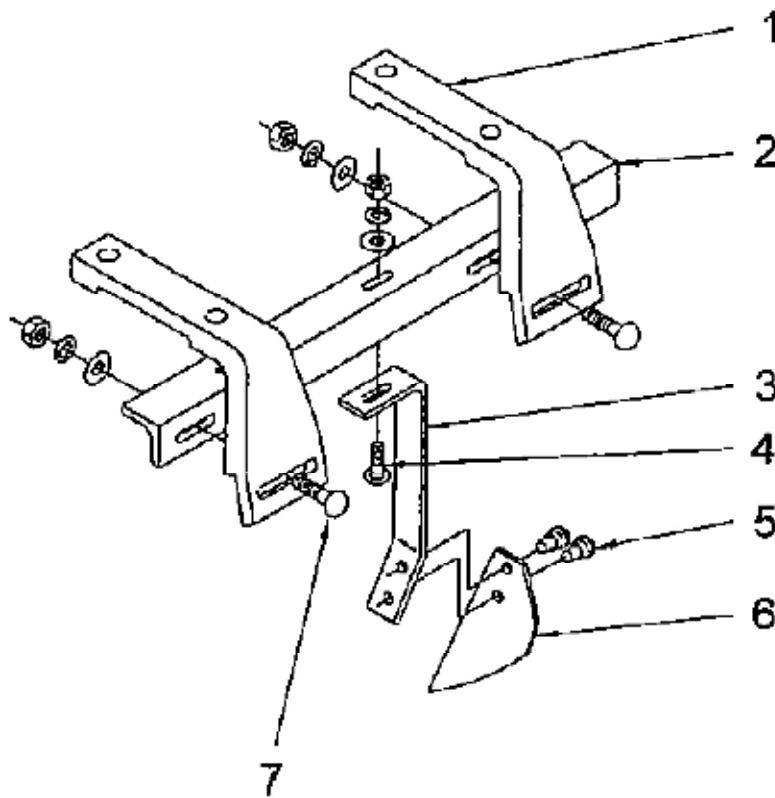

FIGURE 16 - SCRAPER COMPONENTS RIGID DELTA MODELS

Item	Part #	Description
1	807874	TOP STRAP CASTING
2	SEE TABLE 4 ON NEXT PAGE	SCRAPER BAR
3	805002	RIGHT FRONT OR LEFT REAR SCRAPER ARM
	805001	LEFT FRONT OR RIGHT REAR SCRAPER ARM
4	303859	BOLT/CARR 1/2" X 1-1/2"
5	804999	SHOULDER RIVET
6	805000	SCRAPER BLADE
7	303860	BOLT/CARR 1/2" X 1-3/4"
	805004	LEFT FRONT OR RIGHT REAR SCRAPER ASSEMBLY (INCL. 5,6,&10)
	805005	RIGHT FRONT OR LEFT REAR SCRAPER ASSEMBLY (INCL. 5,6,&10)

**NOTE:** When ordering scraper components, **LEFT** refers to left front or right rear and **RIGHT** refers to the right front or left rear disc gang on the implement. **LEFT** and **RIGHT** are determined by standing at the rear of the implement and facing it.

**TABLE 4 SCRAPER BAR LISTING (#2 Figure 17)**

<b>Left Hand</b>	<b>Right Hand</b>	<b>Disc Gang Used On</b>	<b>Length</b>	<b>Bearings</b>
807264	807263	4 DISC 4 SCRAPER 8" DISC SPACING	28	2
807266	807265	5 DISC 5 SCRAPER 8" DISC SPACING	36	2
807130	807129	6 DISC 6 SCRAPER 8" DISC SPACING	44	2
807132	807131	7 DISC 7 SCRAPER 8" DISC SPACING	52	2
807134	807133	8 DISC 8 SCRAPER 8" DISC SPACING	60	2
807136	807135	9 DISC 9 SCRAPER 8" DISC SPACING	68	3
807138	807137	10 DISC 10 SCRAPER 8" DISC SPACING	76	3
807140	807139	12 DISC 12 SCRAPER 8" DISC SPACING	92	3
807268	807267	4 DISC 3 SCRAPER 8" DISC SPACING	23	2
807270	807269	5 DISC 4 SCRAPER 8" DISC SPACING	31	2
807142	807141	6 DISC 5 SCRAPER 8" DISC SPACING	39	2
807144	807143	7 DISC 6 SCRAPER 8" DISC SPACING	47	2
807146	807145	8 DISC 7 SCRAPER 8" DISC SPACING	55	2
807148	807147	9 DISC 8 SCRAPER 8" DISC SPACING	63	3
807150	807149	10 DISC 9 SCRAPER 8" DISC SPACING	71	3
807152	807151	12 DISC 11 SCRAPER 8" DISC SPACING	87	3
807272	807271	3 DISC 3 SCRAPER 9" DISC SPACING	22	2
807274	807273	4 DISC 4 SCRAPER 9" DISC SPACING	31	2
807276	807275	5 DISC 5 SCRAPER 9" DISC SPACING	40	2
807154	807153	6 DISC 6 SCRAPER 9" DISC SPACING	49	2
807156	807155	7 DISC 7 SCRAPER 9" DISC SPACING	58	2
807158	807157	8 DISC 8 SCRAPER 9" DISC SPACING	67	2
807160	807159	9 DISC 9 SCRAPER 9" DISC SPACING	76	3
807162	807161	10 DISC 10 SCRAPER 9" DISC SPACING	85	3
807164	807163	11 DISC 11 SCRAPER 9" DISC SPACING	94	3
807278	807277	4 DISC 3 SCRAPER 9" DISC SPACING	25	2
807166	807165	5 DISC 4 SCRAPER 9" DISC SPACING	34	2
807168	807167	6 DISC 5 SCRAPER 9" DISC SPACING	43	2
807170	807169	7 DISC 6 SCRAPER 9" DISC SPACING	52	2
807172	807171	8 DISC 7 SCRAPER 9" DISC SPACING	61	3
807174	807173	9 DISC 8 SCRAPER 9" DISC SPACING	70	3
807176	807175	11 DISC 10 SCRAPER 9" DISC SPACING	88	3

**NOTE: When ordering scraper components, LEFT refers to left front or right rear and RIGHT refers to the right front or left rear disc gang on the implement. LEFT and RIGHT are determined by standing at the rear of the implement and facing it.**

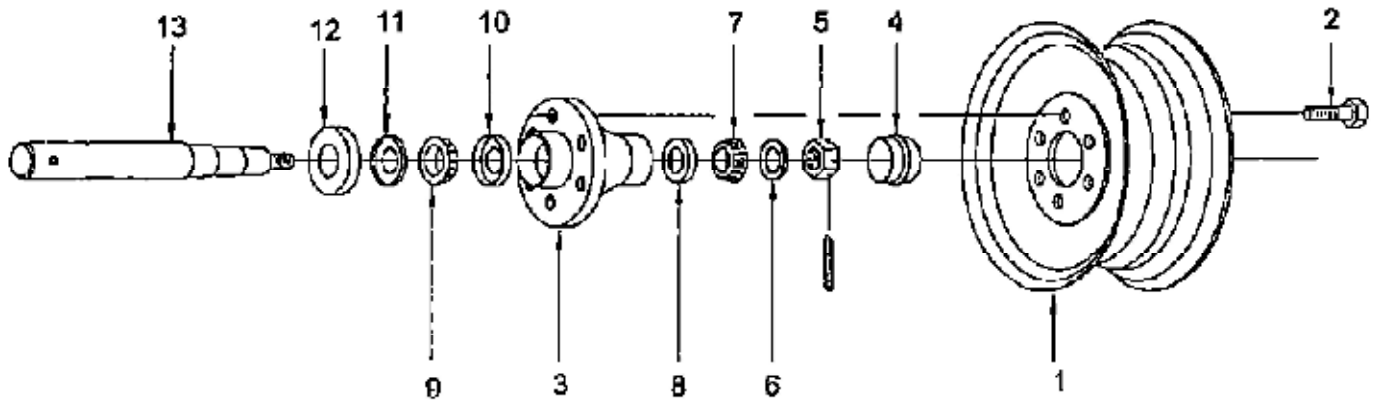
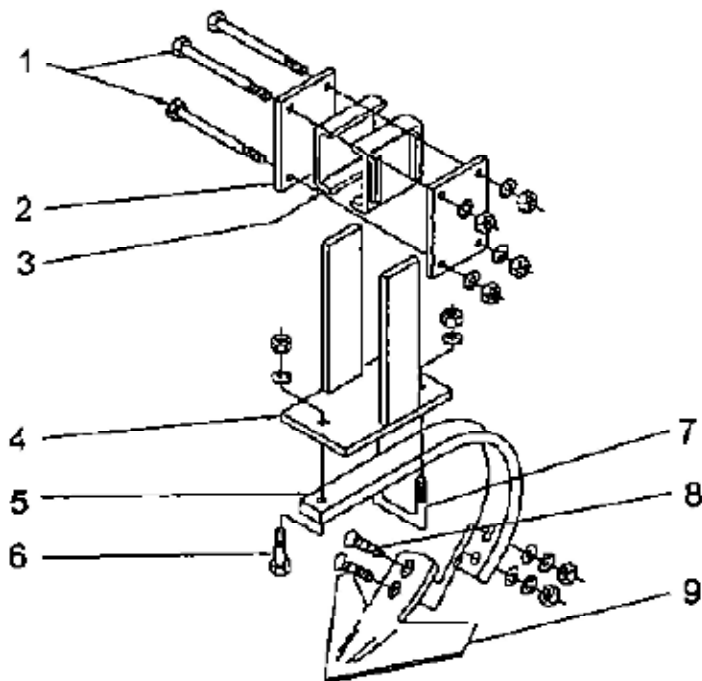

FIGURE 17 - WHEEL COMPONENTS

Item	Part #	Description	Qty
1	206861	RIM/WHEEL 15" X 8"	1
2	403817	LUG BOLT 1/2-20UNF X 1-1/2"	6
3	204516	WHEEL HUB WITH CUPS (INCL. 8 & 10)	1
4	204523	HUB CAP	1
5	304037	NUT/HEX SLOTTED 7/8"	1
	304094	COTTER PIN/COTTER 5/32" X 1-1/4"	1
6	211422	WASHER/FLAT HARDENED	1
7	204524	CONE/BEARING 14137A	1
8	203021	CUP/BEARING 14276	1
9	204526	CONE/BEARING 342A	1
10	204525	CUP/BEARING 332	1
11	204627	SEAL/GREASE CR 18823	1
12	204520	DUST COLLAR	1
13	210685	SHORT WHEEL SPINDLE USED ON WINGS AND OUTSIDE MAIN FRAME	1
	211284	LONG WHEEL SPINDLE USED ON INSIDE MAIN FRAME	1
	809149	SPINDLE USED ON MODELS 58606,58706,58506,58122,58522	1
	207889	COMPLETE HUB ASSEMBLY (INCL. 2-10 & 13)	-
	207937	BEARING KIT (INCL. 7-11)	-



Item	Part #	Description	Qty
1	303711	HHCS 3/4" X 7"	4
2	209777	CONNECTOR PLATE	2
3	209774	CUFF ASSEMBLY	2
4	209772	SHANK CONN. ASSY.	1
5	207434	16" SHANK	1
6	303878	HHCS 5/8" X 2-1/2"	1
7	603984	U-BOLT	1
8	303910	BOLT/PLOW 1/2" X 2-1/2"	2
9	209408	8" SWEEP	1
299093		COMPLETE ATTACHMENT	

FIGURE 18 - RIGID BALK BREAKER ATTACHMENT

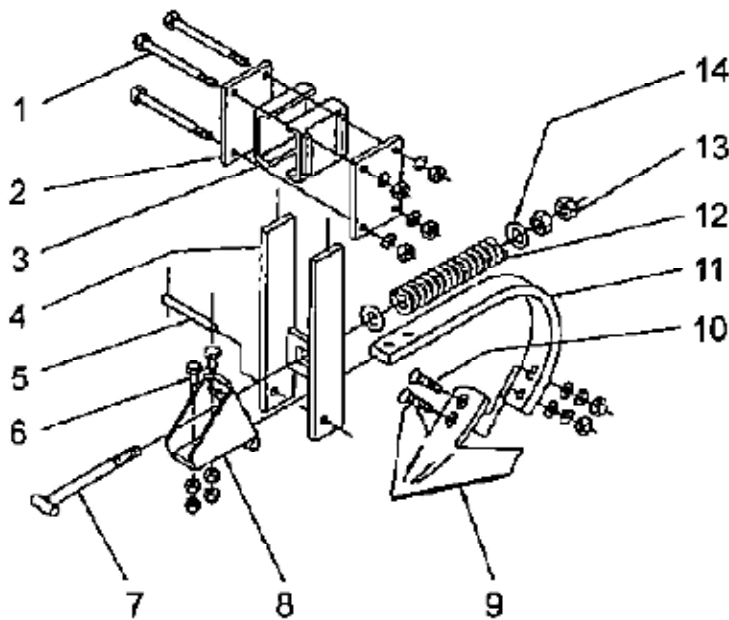

Item	Part #	Description	Qty
1	303711	HHCS 3/4" x 7"	4
2	209777	CONNECTOR PLATE	2
3	209774	CUFF ASSEMBLY	2
4	209898	ANCHOR ASSY	1
5	209905	PIN	1
	304137	COTTER PIN	2
6	303853	HHCS 1/2" x 2"	2
7	209903	SPRING BOLT ASSY.	1
8	209897	SHANK HINGE ASSY.	1
9	603326	8" SWEEP	1
10	303898	BOLT/PLOW 3/8" x 1-1/4"	2
11	604851	SPRING SHANK	1
12	206612	SPRING	1
13	304064	JAM NUT	2
14	205163	SPECIAL FLAT WASHER	2
299099		COMPLETE ATTACHMENT	

FIGURE 19 - SPRING BALK BREAKER ATTACHMENT

<b>FURROW FILLER KIT</b>			
Item	Part #	Description	Qty
1	303651	HHCS 1/2" x 1-1/2"	3
	303655	WASHER/LOCK 1/2"	3
	304007	NUT/HEX 1/2" NC	3
2	208829	SPACER SPOOL	1
3	204900	16" DISC	1
	204001	18" DISC	1
4	203988	BUTT PLATE	1
5	303950	WASHER/LOCK 7/8"	1
6	304010	NUT/HEX 7/8" NC	1
	201048	KIT WITHOUT DISC	2

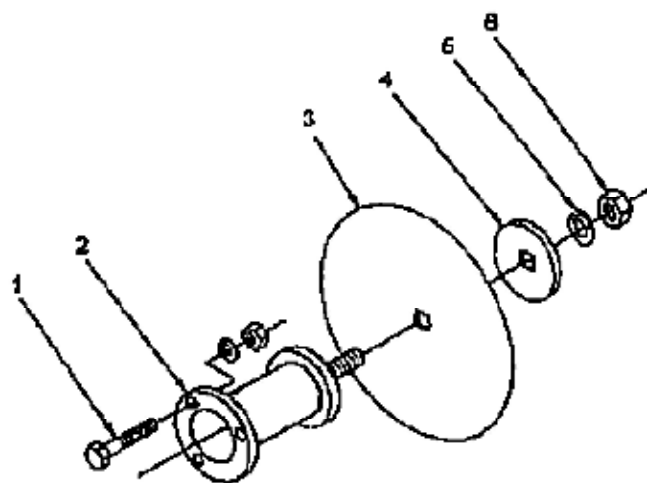

FIGURE 20 - FURROW FILLER KIT\*\*

\*\* The furrow filler kit should not be used on small frame units with 6 and 7 disc wings due to interference when wings are folded.

<b>FURROW SCRAPER KIT</b>			
Item	Part #	Description	Qty
1	303859	Garr. BOLT 1/2"X1-1/2"	4
	303955	LOCK/WASHER 1/2"	4
	304007	HEX NUT 1/2" - NC	4
2	807096	L.H. SCRAPER ARM	1
	807097	R.H. SCAPER ARM	1
3	805000	SCRAPER BLADE	2
	804999	SHOULDER RIVOT	4
4	809693	SCRAPER BAR	2
	809694	COMPLETE SCRAPER KIT	

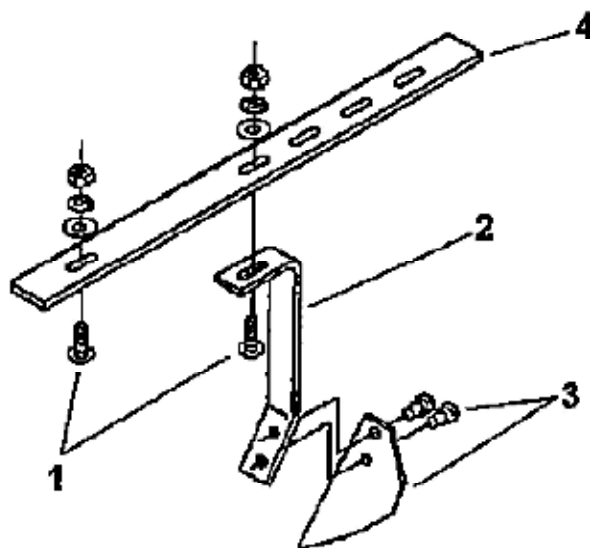

FIGURE 21 - FURROW FILLER SCRAPER KIT



209953	GANG BOLT WRENCH
--------	------------------



